



TESCO METERING

New Ways to use Automation and AI In Meter Shop Operations



EEI Spring Transmission, Distribution, and
Metering Conference 2026

Special Projects Working Group
Tuesday, 3:00 pm
April 28, 2026

Tom Lawton, President – TESCO Metering

Artificial Intelligence is quickly moving from novelty to essential for business operations.

This presentation discusses how AI is starting to be used in Metering and some of the potential that exists for coupling AI with ever-improving Meter Analytics as we take greater advantage of the copious data generated by AMI and move into AMI 2.0.

This presentation will review:

- What AI is
- The various platforms that exist
- How AI is intended to be used
- What AI is not
- Case studies in how we are already using AI to improve operations, reduce cost, and improve efficiency



The introduction in 2007 of mass deployed Advanced Meter Infrastructure (AMI) systems promised more effective and more efficient Meter Service Operations.

This was to be accomplished in a variety of ways starting with:

- No need to manually read meters (if AMR had not previously been deployed at the utility)
- No need to roll a truck to perform a disconnect or a reconnect
 - (1S, 2S, 12S forms initially now 2SE & 16S forms)
 - Note: Earliest deployments did not have this feature fully operational or may not have elected to include. Became standard within a few years
- Improved ability to detect and respond to outages
- Increased Alarms, Flags, and Events (AFEs) to detect theft or other events that may require a truck roll to investigate and potentially correct
- Superior capability to detect (and eventually capture) unbilled energy usage
- Ability to understand customer usage and make improved energy decisions with load profile / interval data

And with all of this came a promise of “Additional Capabilities and additional Operating data.”



AMI systems are deployed in nearly 90% of the US and Canada markets. Electric Utilities now collect hundreds of millions of AFEs – alarms, flags, and events along with readings and interval data every day from sources such as the following:

- Meters (status, manufacturer, purchase date, events such as reprogramming notifications and tamper alerts)
- Transformers (ID, circuit section, circuit ID)
- Service points
- Customer accounts (type, status, billing cycle)

Utilities, Meter OEMs, and Meter service providers have been developing, using and improving a variety of reporting on this data and have been reaping operational benefits.



- We digitized meters – not the shops, processes, and operations.
 - AMI is widely deployed
 - There is massive data generation
 - Meter shops are still mostly manual
 - Labor constraints are rising
 - Backlogs are increasing



Artificial Intelligence (AI)

The Field of Computer Science that seeks to create intelligent machines that can replicate or exceed human intelligence.

Brief history of AI

Artificial Intelligence

Machine Learning

Deep Learning

Generative AI



1956

Artificial Intelligence

The field of computer science that seeks to create intelligent machines that can replicate or exceed human intelligence.



1997

Machine Learning

Subset of AI that enables machines to learn from existing data and improve upon that data to make decisions or predictions.



2017

Deep Learning

A machine learning technique in which layers of neural networks are used to process data and make decisions.



2021

Generative AI

Create new written, visual, and auditory content given prompts or existing data.

ARTIFICIAL INTELLIGENCE – REPLACING HUMANS?

AI and Robots
Will Take All
Our Jobs!



THE FISCAL TIMES
Free Newsletter | Budget | Taxes | Health Care | Social

POLICY + POLITICS
Millennials vs. Robots—Who Will Win the Jobs?





TESCO METERING

MISCONCEPTIONS ABOUT TECHNOLOGY & AI OVER TIME

...1812...



Reward Poster for Luddite Attacks Near Leeds, March 1812

1935...

Robot-Brains Outdo Man's Mind in Speed and Accuracy of Results

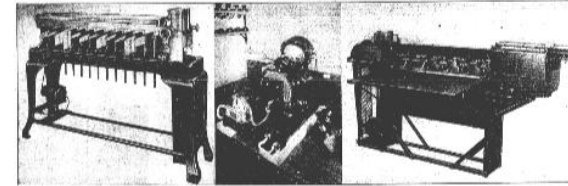

'Thinking Machines' Replace the Thinker

They Predict Tides, Pick Criminals' Fingerprints, Calculate Mathematical Problems, and Perform Amazing Tasks.

Washington Post, January 1935

1960...

Robots' Rise

They Bid for Big Jobs Both in Outer Space And in U.S. Factories

A.M.F. Designs Robot to Send To Moon; G.E. Works on One to Paint New Autos

"But these machines, nevertheless, are true robots—automatic devices that perform human functions or operate with seemingly human intelligence."

Wall Street Journal, July 1960

1980...

DETROIT — Technological innovation is widely billed as a miracle cure for the United States' economic ills. In other words, however, may be far from benign. The introduction of revolutionarily new technologies such as robots — versatile computer-controlled mechanical arms — raise two pointed possibilities: sizeable losses of jobs and a deteriorated quality of working life.

The threat of lost jobs, although also dependent on social and economic factors, is especially critical. Auto makers are already buying robots in record numbers, despite a downturn that has resulted in 230,000 jobless layoffs. From the following Chrysler Corporation has added 1% of those

A Robot Is After Your Job

By Harley Shaiken

proportionate impact on a few key industries. Robots that began work tomorrow will still be on the job in 1990, giving us a robot population of

Such a socially destructive use of technology need not be inevitable. Jobs for workers displaced and improved working conditions for those who remain ought to be a condition for the introduction of robots. Productivity gains, for example, could translate into a shorter work week at the same pay rather than into fewer jobs. Technology could be designed to enhance human skill and

Artificial Intelligence (AI), changing everything

Like the cell phone before AI and the PC before that, these technologies are changing and have changed how we interface to our world, how we work, how we play and in short, how we live our lives.

In many ways this is not dissimilar to how AMI has changed our metering profession. AMI has changed everything. AI is in the process of also changing everything – in the rest of our lives as well as in our professional metering lives.

- Meter Shop Automation
 - Automated intake, sorting, and testing
 - AI-assisted inspection and defect detection
- AMI Alarms Flags and Events (AFEs)
 - Convert AFEs into actions
 - Identify safety hazards & enable proactive maintenance
- Revenue Protection
 - Detect theft / unbilled energy & identify anomalies
 - Improve billing accuracy and recovery
- Inventory Optimization
 - Standardize forms and SKUs
 - Forecast demand with AI & reduce carrying costs
- Field Operations
 - AMI triggered dispatch
 - Feedback loop into meter shops and analytics



Meter Shop Operations

- Intake and sorting
 - Automated Classification
 - New / re-use / retire / damaged
 - Image based detection
 - Historical failure pattern recognition and mapping
- Testing and validation
 - Automated scripting
 - AMI Communication Checks
 - Functional validation
 - Standardized SOP execution
 - Reduced technician variability



Meter Shop Operations

- Inspection and Data Capture
 - As-found images
 - AI tagging of
 - Damage
 - Tamper indication
 - Wear patterns
 - Automated record keeping
- Integration into the meter Enterprise Asset Management (EAM)
 - Automated work orders
 - Real time asset updates and EAM entry
 - AMI data inclusion into EAM

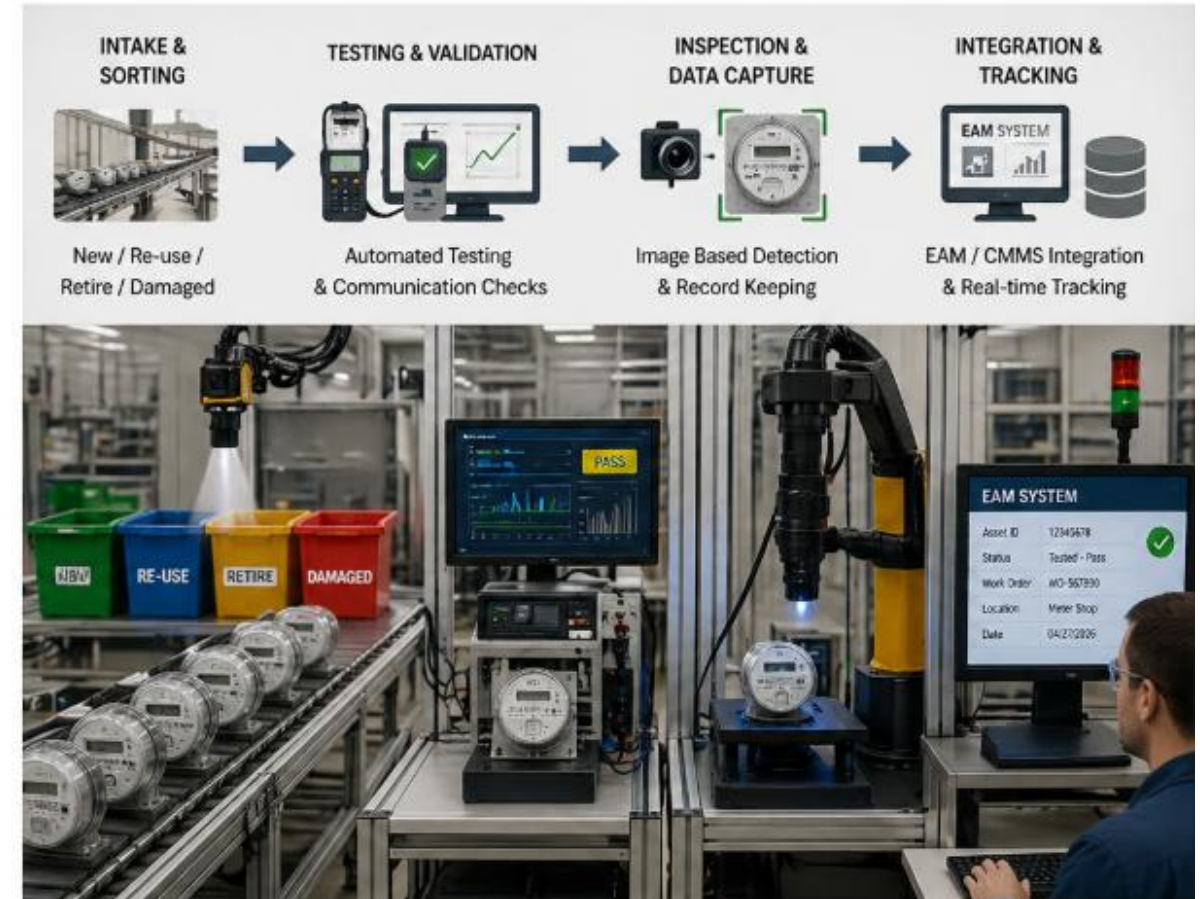

AMI generates

- AFEs
- Voltage Data
- Usage patterns

AI converts signals into

- Work Orders
- Alerts
- Operational Decisions

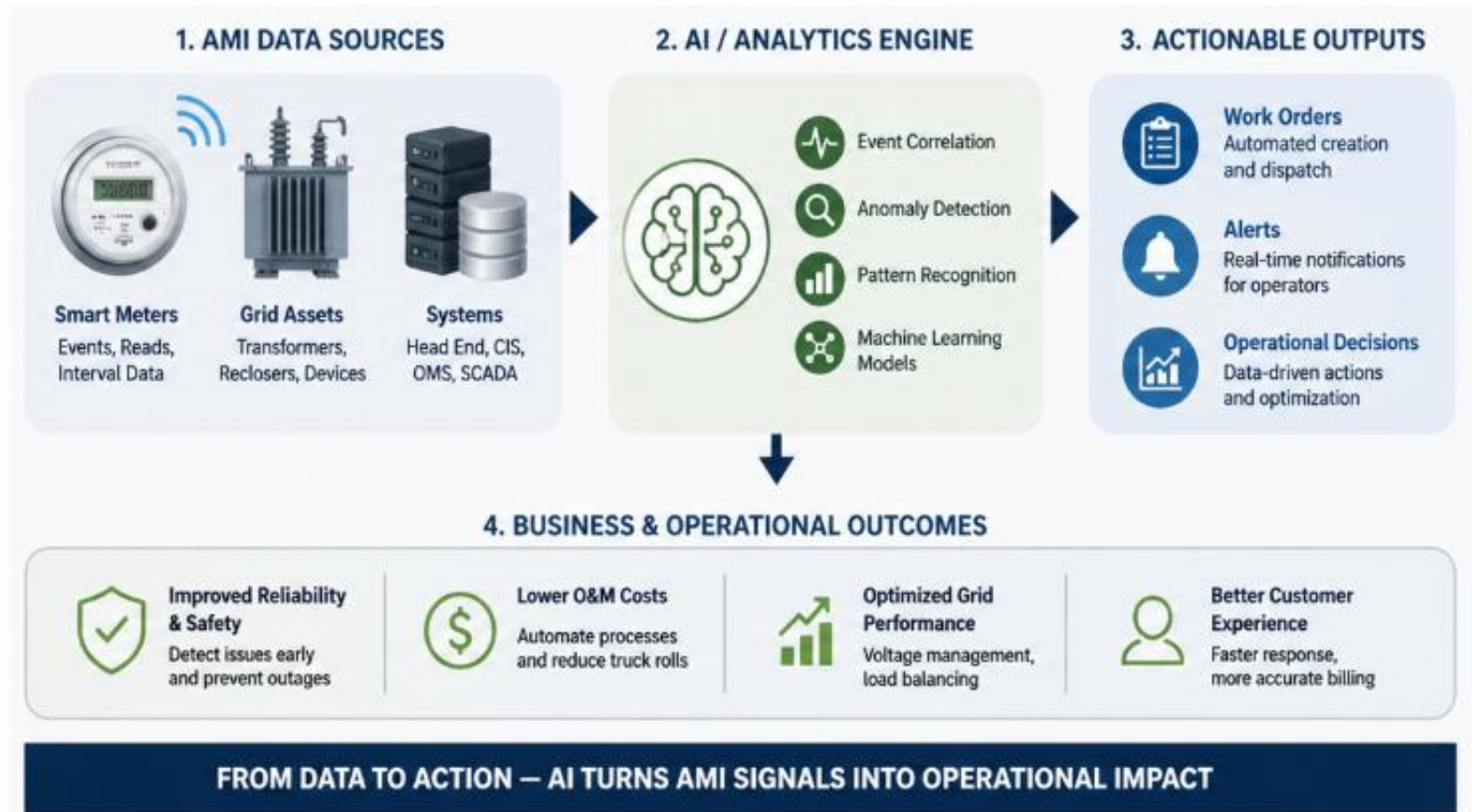

Oversized Transformer Reporting

Platforms used:

Meter Manager – has all physical assets at every location including the instrument transformers.

Consumption information from the head end – in this case a Legacy Silver Spring / Itron Open Way head end system.

We can use AI to automate this and create reports at whatever frequency we would like based on estimated lost revenues.

Oversized Transformer Reporting

Output:

A monthly report of the most egregiously oversized transformer installations with usage going back over the past two years to demonstrate and estimate lost revenue.

Use:

Field services receives monthly work orders to replace the instrument transformers with appropriately sized transformers. Extended range transformers further improve the effectiveness of the monthly billing.



Oversized Transformer Reporting

Results:

A steady increase in monthly revenue gains on every Commercial/Industrial account addressed. Payback for the work is under three months in every case as there are so many oversized accounts.



Micro Arc (RF) Detection and Reporting

Platforms used:

Itron Open Way head-end and L+G Gridstream head-end with customized analytic software – receive alarm data on the RF signature of electrical arcs in or around the service.

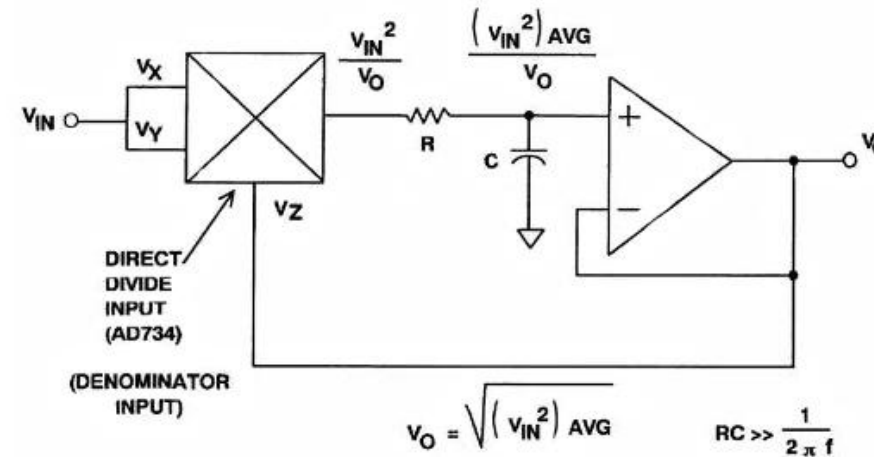
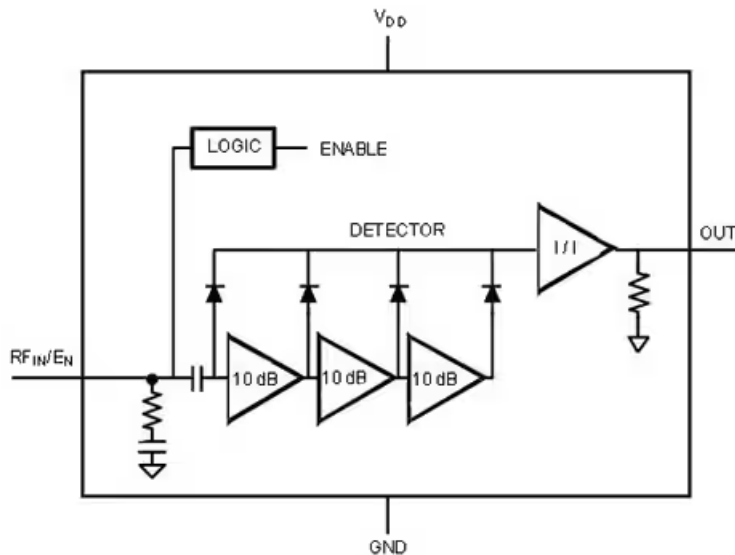

Micro Arc Detection and Reporting

Output:

A weekly report identifying sites with RF detect (micro arc) alarms that fit an identified pattern. Determine which sites to send a Meter tech with RF detection equipment to detect where the RF signals may be coming from as they typically are not coming from the meter but are coming from relatively close by (with 100 feet).

Use:

Field services inspection involves a visual detection as well as the use of RF detection equipment to pinpoint the source of the problem.

RADAR ENGINEERS



MODEL M331

MINI RFI LOCATOR

Micro Arc Detection and Reporting

Results:

Safety hazards found in the field were initially anticipated to be only failed socket jaw (hot socket) events, but this proved to be only a fraction of what was found. Some of the various safety related issues discovered in the field include;

- Failed meter socket jaw
- Frayed and breaking weather head connections
- Arcing on a customer circuit on the customer side of the service panel in the home
- Arcing at the connection to the Distribution transformers closest to the house and failing Distribution Transformers
- Arcing in the manual disconnect mechanism of the meter box
- Frayed and failing wires between the socket and the service panel in the home

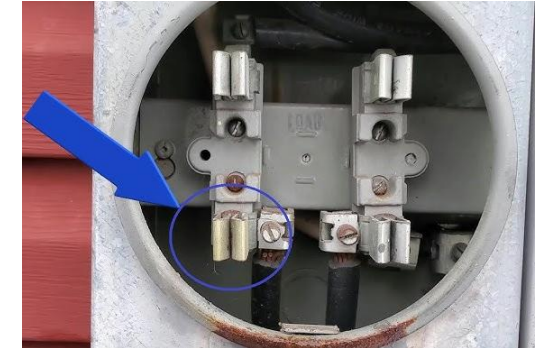

Voltage Optimization

Platforms used and background:

Raw data from metering end points brought back in near real time. This can be accomplished much easier using AMI 2.0 to filter out standard voltage readings that are not an issue and only send back voltage readings that are outside the norm desired or expected.

AMI 2.0 will allow for real time voltage readings across the entire service territory without inundating the head end with data. This data can then be used for Conservation Voltage Reduction (CVR) and Volt/VAR Optimization (VVO) programs. Both can provide significant improvement to the distribution system's performance and reduce cost for the utility.

CVR is a technique where utilities lower distribution voltage to reduce energy consumption without affecting service quality. Using AMI real time AMI data and AI utilities can optimize voltage dynamically instead of simply using a fixed set point. This has proven to reduce energy consumption by 1 to 3% per volt.



Conservation Voltage Reduction (CVR) in action

Pacific Gas & Electric (PG&E)

- Used several thousand metering end points to provide near-real time voltage information at customer end points.
- Deployed Automated Voltage Control systems at substations
- Applied analytics software to continuously adjust voltage based on the real-time meter data
- Coordinated CVR with demand response programs to ensure that voltage adjustments aligned with peak demand reductions

Results:

- Achieved a 1 to 3% reduction in energy demand per volt reduction
- Improved energy efficiency across more than 500 circuits
- Improved customers satisfaction with better power quality and fewer voltage related issues



Volt/VAR Optimization (VVO)

Results:

This automated control allows utilities to optimize power flow and reduce line losses. This also allows for **Over Voltage detection and correction** preventing equipment damage and customer complaints as well as **Undervoltage issues** that allow customers to have sufficient voltage to always power their appliances, HVAC systems and other equipment properly and extending their life. The **Phase imbalance corrections** applied to the system this way corrects a host of power quality issues and energy waste due to better power factors through these automated corrections.

This enhancement of grid automation through AMI and AI provides:

- Energy Savings without affecting the customer experience
- Line Loss reduction reducing distribution costs
- Improved Power Quality
- Better DER integration by stabilizing voltage for renewables on the other side of the meter

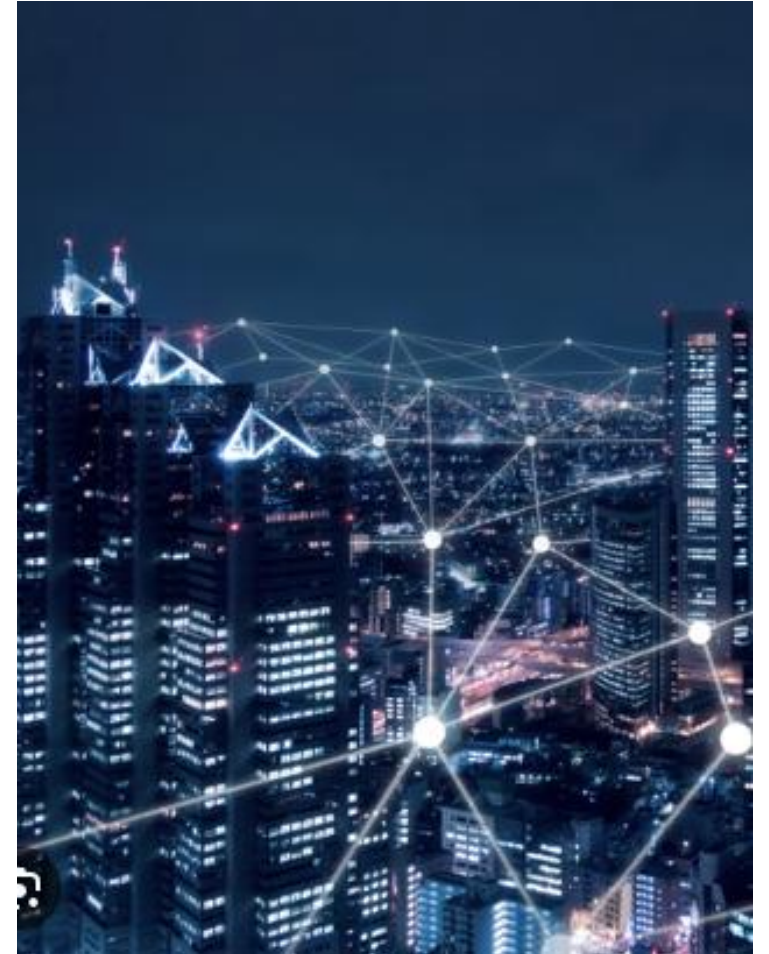

VVO in action

Duke Energy

- Installed voltage regulators, capacitor banks, and load tap changers (LtC's) at substations
- Used AMI to collect real-time voltage readings from the metering end points
- Integrated the AMI data with a Distribution Management System and an Advanced Distribution Management System to enable dynamic voltage adjustments
- Used machine learning algorithms to predict voltage fluctuations and make preemptive adjustments.

Results:

- 2.5 to 3% reduction in energy consumption without affecting service quality
- Reduced line losses by 1 to 2%. This was worth millions in cost savings annually.
- Improved power quality and reduced voltage related complaints from customers.



- Transformer Overload Identification
- Behind The Meter Identification
- Weather Sensitivity
- Wholesale Settlements
- Mark-to-Market
- Suitability for DER
- Profitability
- Grid Loading
- Demand Forecast
- Generation Forecast
- ISO Forecast
- Net Open Position
- Scenario Analysis
- Coincidence Peaks
- Load Optionality
- Grid Constraints Load Scheduling
- Demand Response
- Risk Management
- Decarbonization
- Cost Reduction
- Customer Engagement
- Billing
- Grid Dispatch & Planning

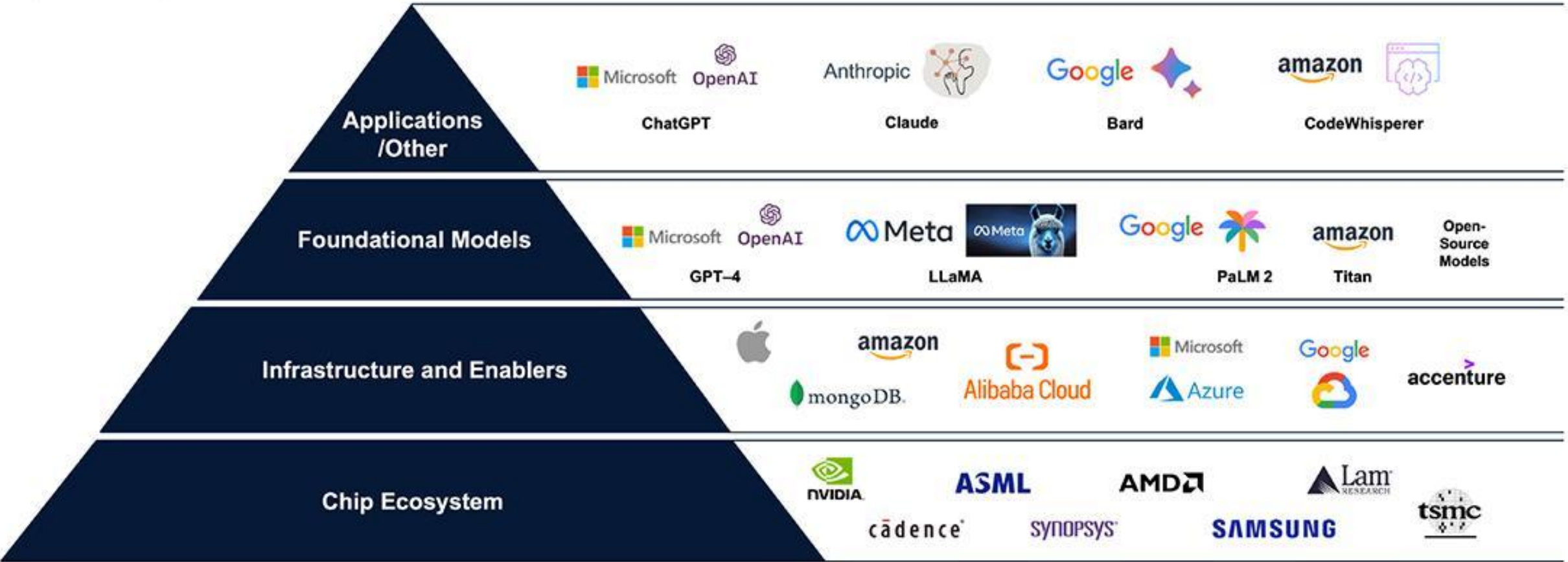

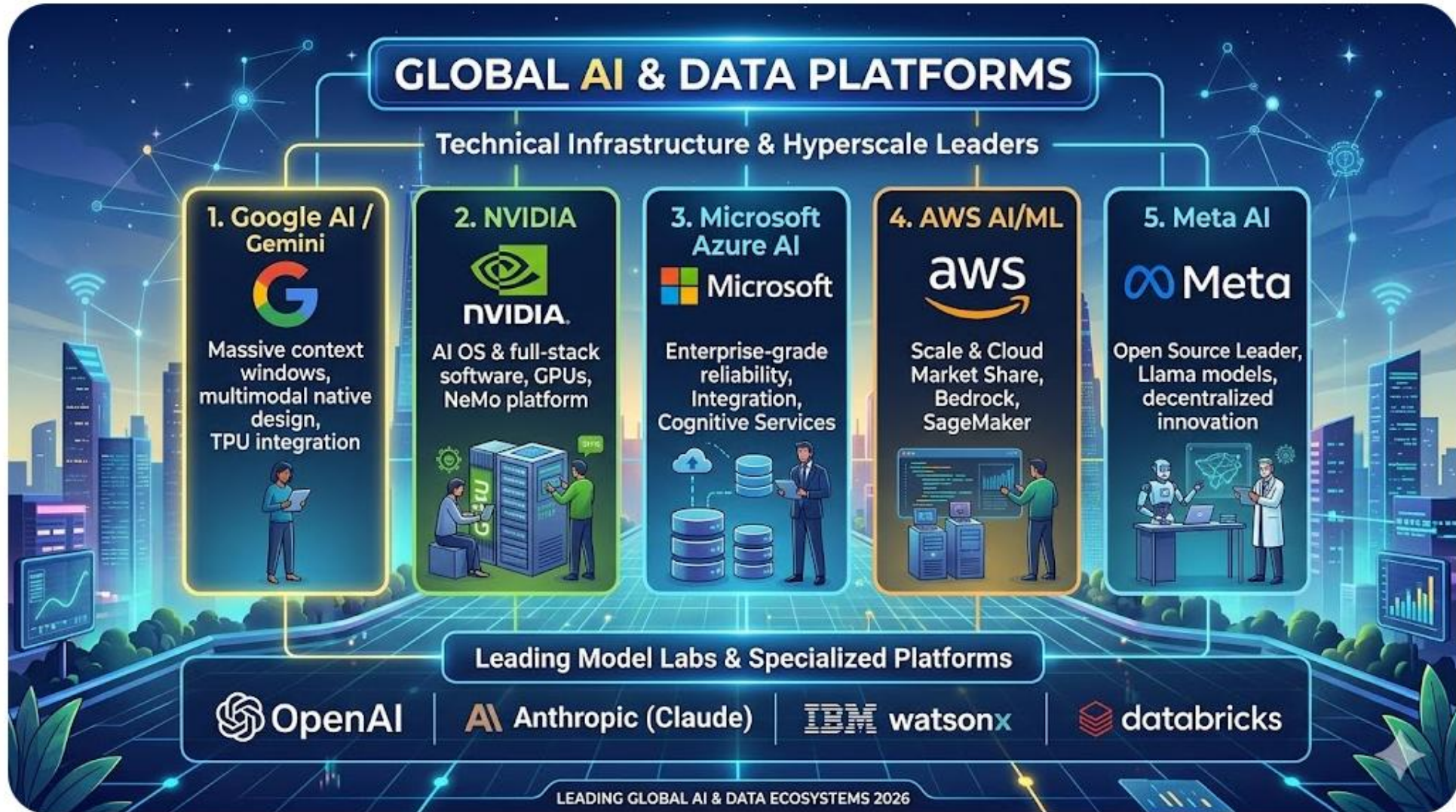

Tesco Software Teams:

1. Increased productivity of software development teams (Meter Manager, TDM, Adaptiv) and the Adaptiv support teams.
2. Doubled the number of users in one year for Adaptiv and added close to ten million metering assets for Meter Manager.
3. Rewrote large sections of the Adaptiv platform, wrote Meter Manager 3.0, and released new revisions for TDM in a series of monthly sprints. This ability to move so much faster with the assistance of AI significantly reduced system errors and User errors for all three platforms - aka – making the applications bulletproof.

Better and Faster with the same budget!

Tesco Engineering Teams:

1. Education for the LRE – lead responsible engineer and assistance through the New Product Development tollgate process from design iterations to DVT test plans to QA/C on documentation against requirements.
2. Onboarding and training for new hires – audio books – custom made videos – content generation.
3. Research and engineering analysis – what used to take 3-4 hours of research can be done in 15-30 minutes across “Deep Research” and a series of prompts.

Better and Faster with the same budget!

Tesco Operations Teams:

1. Inventory and work order reporting and analysis from ERP system.
2. Business analytics from enterprise ticketing systems – service data to calibration data to product enhancement requests.
3. Financial reporting on invoicing, revenue, and order backlogs by month, quarter, and year.

Better and Faster with the same budget!

Notebook LM & Private Library Examples:

1. Standards research – loading of handbook for electricity metering, UL standards, ANSI C1219 documents, and NEC rules in a notebook lm library = meter engineer chatbot = faster metering assistance, document scanning, standards research.
2. Engineering SOPs, process flows, and procedures loading in a notebook language model (lm) library = auto-generated SOPs, video + slide + audio training, & faster onboarding.
3. Content generation and analysis of TESCO product manuals, specification sheets, training videos = faster marketing analysis for engineering support, automated reporting, and improved product quality.

Better and Faster with the same budget!



TESCO METERING

Drive flawless execution in your operations



Right Person



Right Place



Right Time



Right Skills



Right equipment

Increase

Productivity

Service Quality

Accuracy

Resource Utilization

Organization Visibility

Lower Service Cost

Optimize Scheduling and Planning

Online/Offline Mobile

Democratize Knowledge & Competency

Reduce Time to Invoice

AI COPILOT ENABLED

WHAT SHOULD A UTILITY DO NEXT



1. START WITH 2-3 HIGH ROI USE CASES

- AMI Events Analytics (alerts to work orders)
- Meter Shop Automation
- Revenue Protection



2. BUILD THE FOUNDATION

- Connect AMI, Shop, and EAM Data
- Standardize SOPs and data capture
- Establish clear ownership between Ops, IT, and Meter Engineering



3. MOVE FROM PILOT TO PROVING TO SCALE

- Start with a problem
- Prove Value
- Scale



START SMALL. PROVE VALUE. SCALE WITH CONFIDENCE.

STRONGER OPERATIONS. BETTER OUTCOMES.
GREATER VALUE FOR YOUR CUSTOMERS.

ANALYTICS MATURITY CURVE

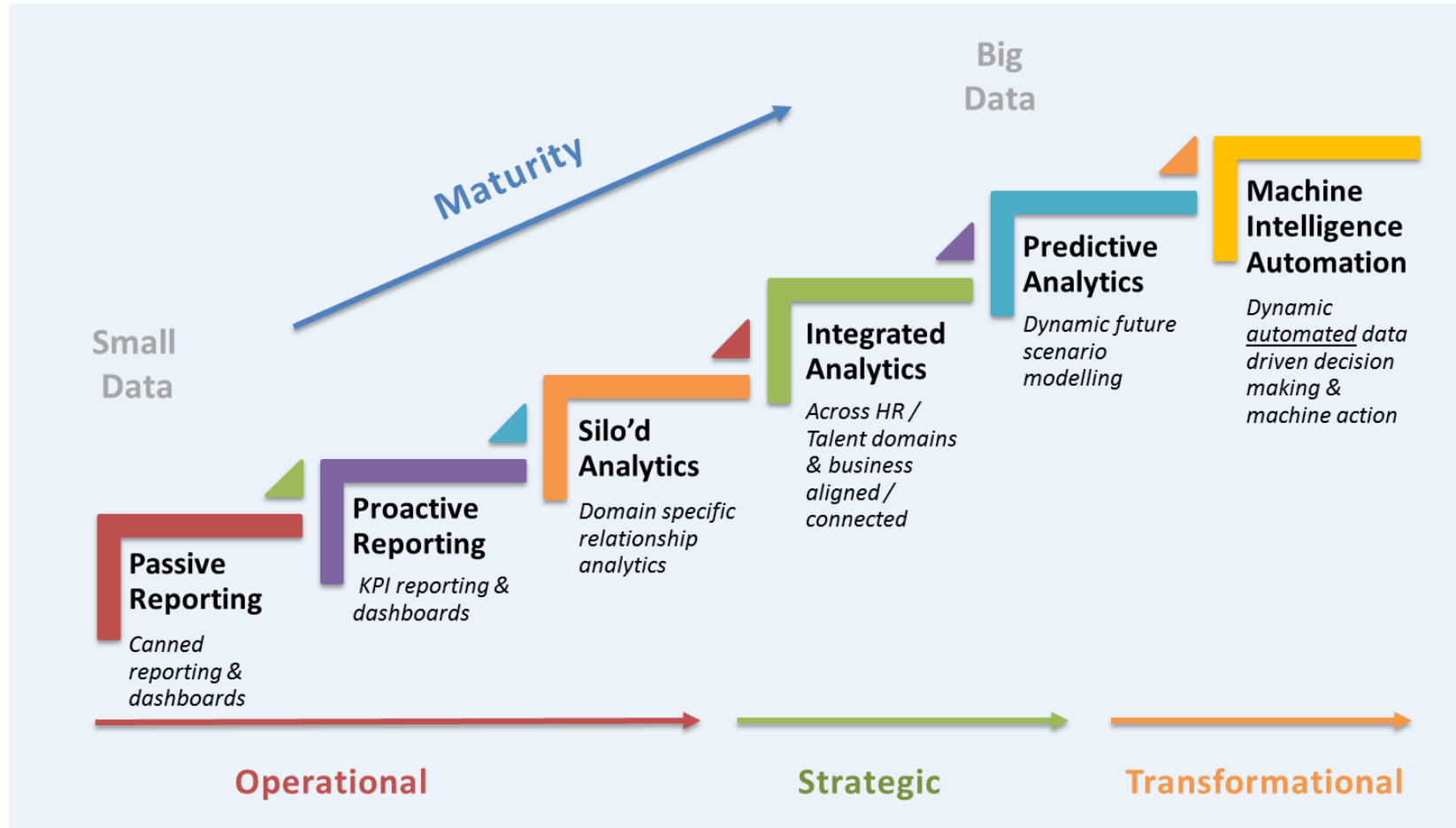



QUESTIONS AND DISCUSSION

Tom Lawton

President

tom.lawton@tescometering.com



TESCO – The Eastern Specialty Company

Bristol, PA

215.228.0500

This presentation can also be found under Meter Conferences and Schools on the **TESCO** website: tescometering.com

PRIOR SLIDES MOVED TO APPENDIX

Foundations of AI

Standard Statistical Techniques and Methods



Probability Theory deals with the uncertainty and likelihood of events.

This is utilized in predictive modeling where AI systems determine the likelihood of events – think speech recognition or predictive text.

$$P(A) = \frac{\# \text{ outcomes in event } A}{\text{total } \# \text{ of outcomes}}$$

Flaw of Averages

“Never try to walk across a river just because it has an average depth of four feet.” —Milton Friedman



<https://web.stanford.edu/~savage/faculty/savage/FOA%20Index.htm>





TESCO METERING

RANDOMNESS AND CHANCE

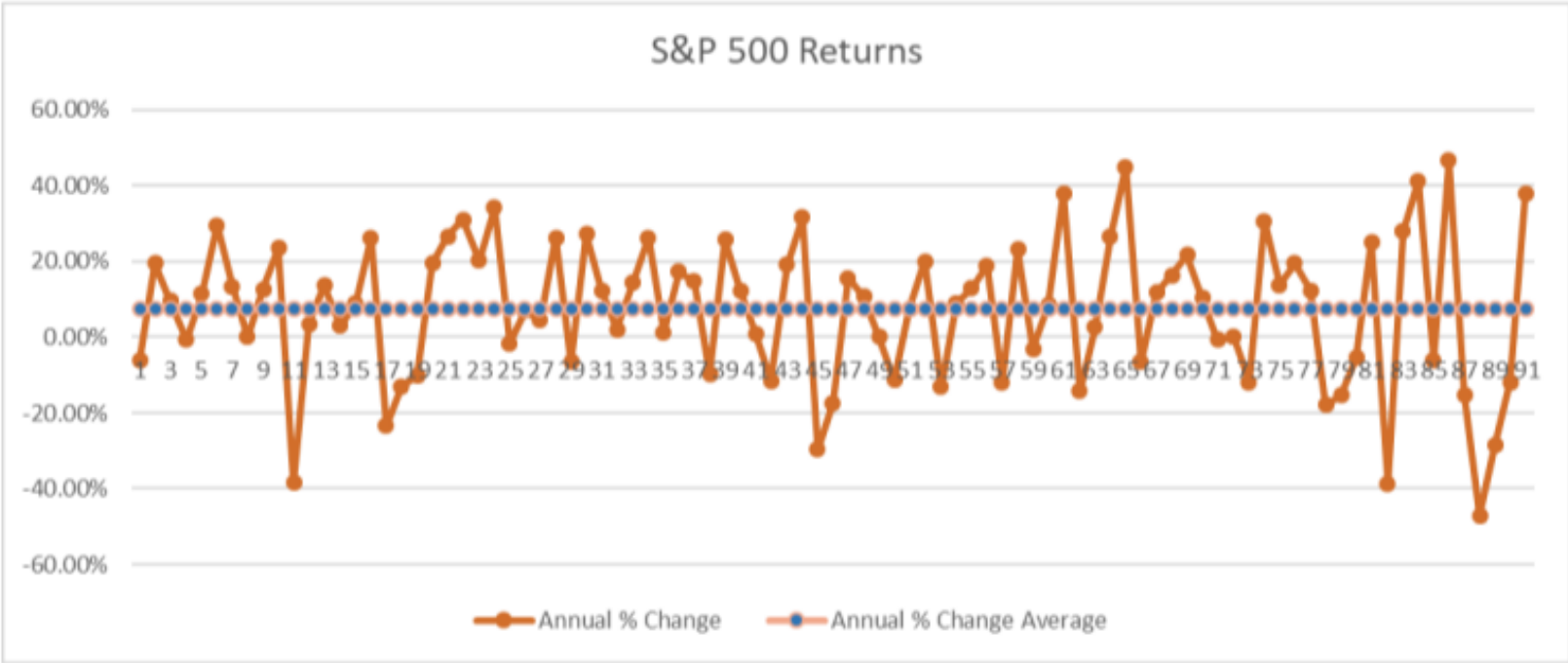

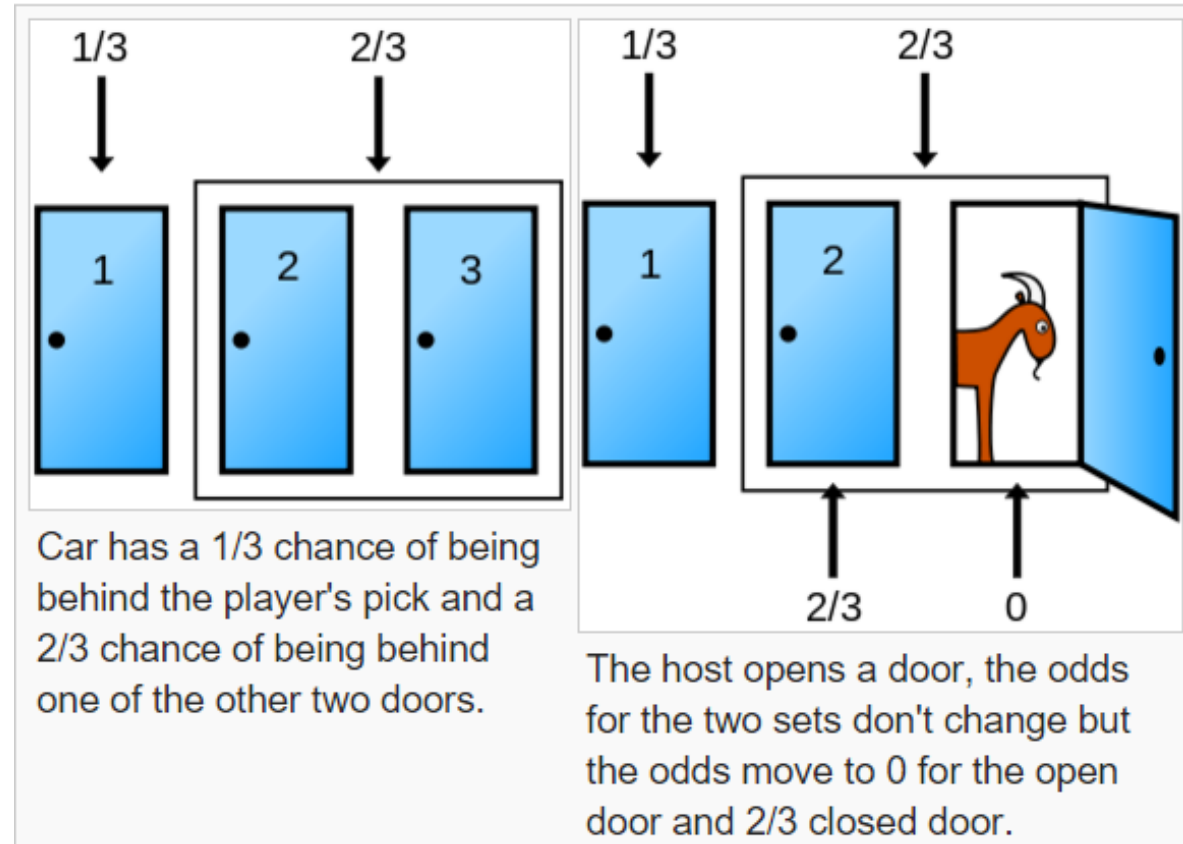

Linear Regression is a method to model relationships between variables.

Used to supervise learning to predict outcomes.

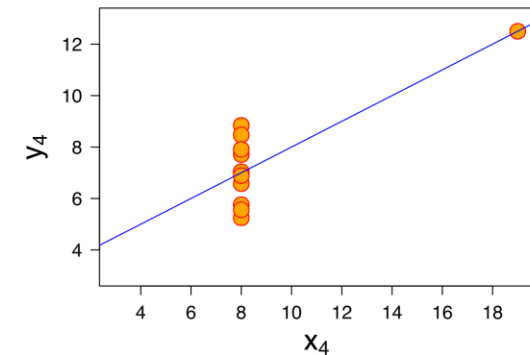
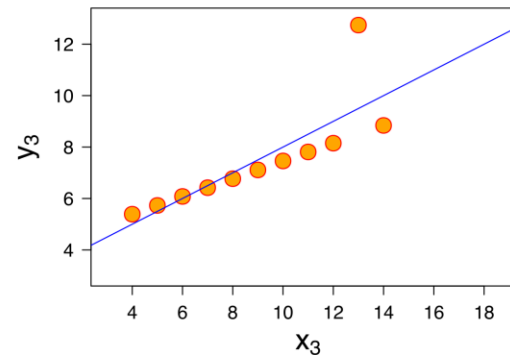
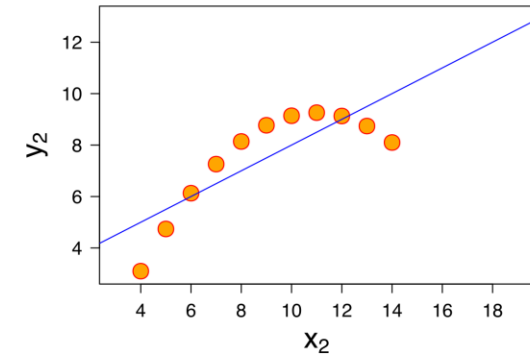
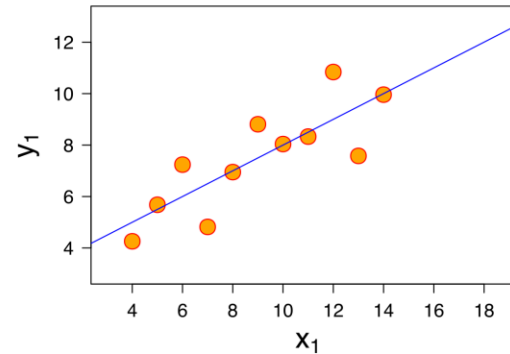

By Anscombe.svg: Schutz(label using subscripts): Avenue - Anscombe.svg, CC BY-SA 3.0, <https://commons.wikimedia.org/w/index.php?curid=9838454>

Statistical Inference is the process of using data analysis to infer properties of an underlying probability distribution.

Allows for conclusions to be drawn about a population based on sample data.

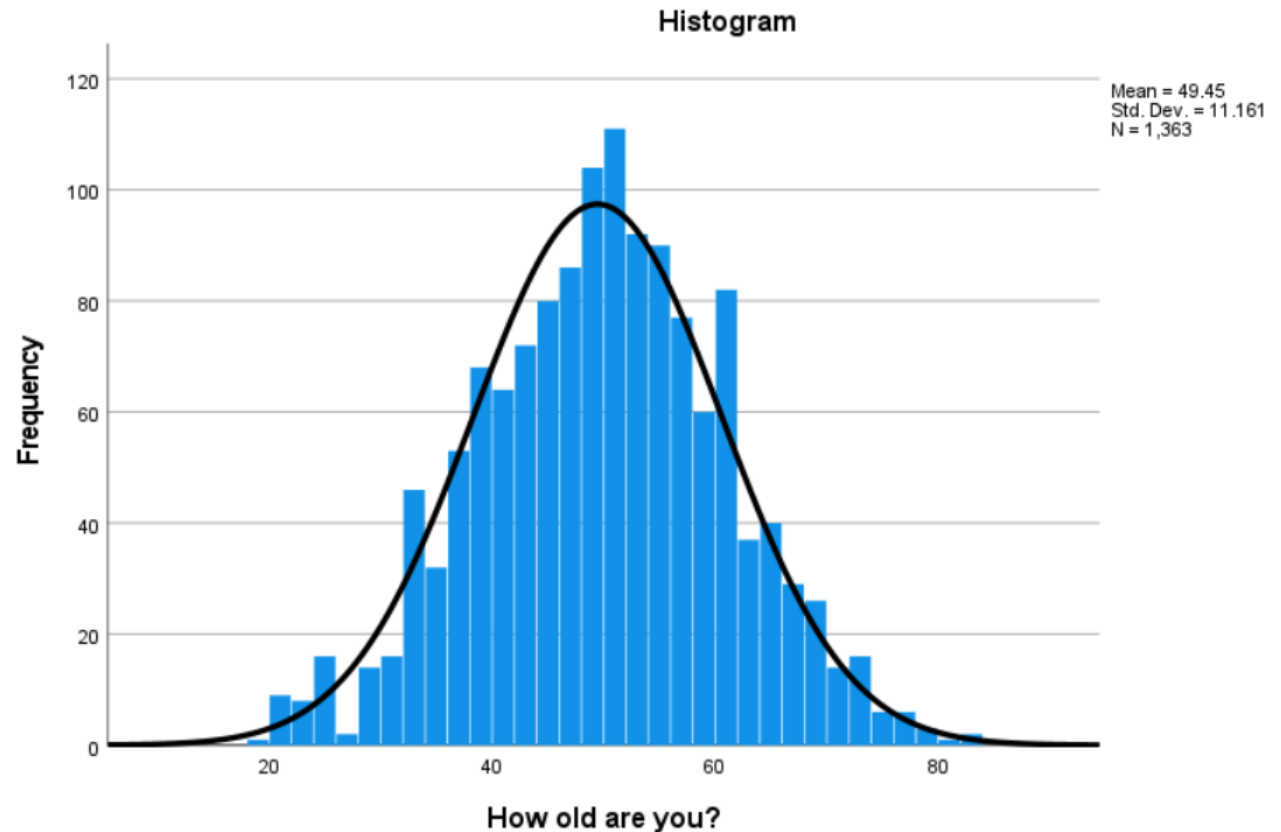

By Psychstudent25 - Own work, CC BY-SA 4.0,
<https://commons.wikimedia.org/w/index.php?curid=117711252>

Hypothesis testing validates assumptions made about data through tests like T-tests or ANOVA.

Ensures the reliability and accuracy of models during training.

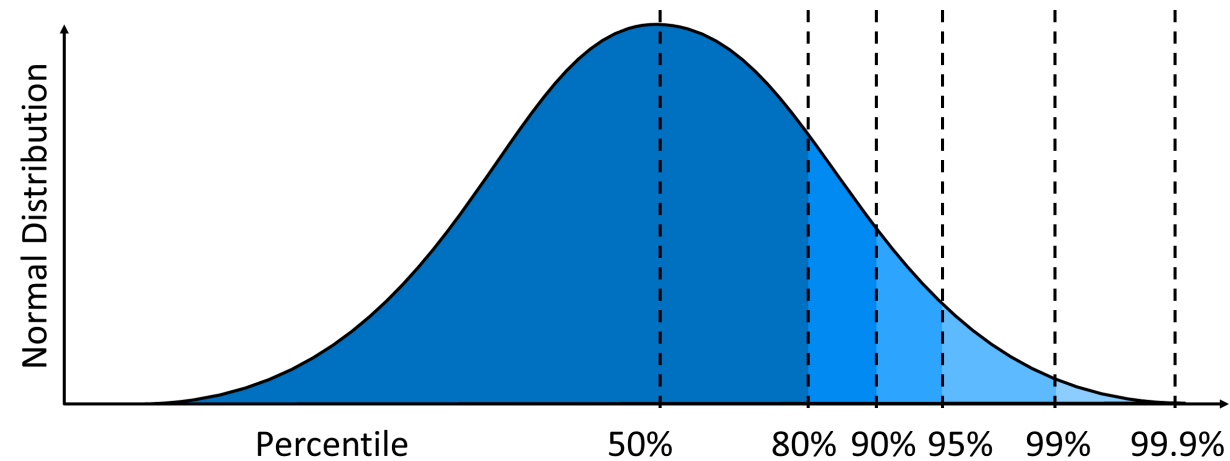

Clustering and classification groups data (clustering) or assigns it to predefined categories (classification).

Techniques used in unsupervised or supervised learning such as K-means (clustering) or Decision Trees (classification).

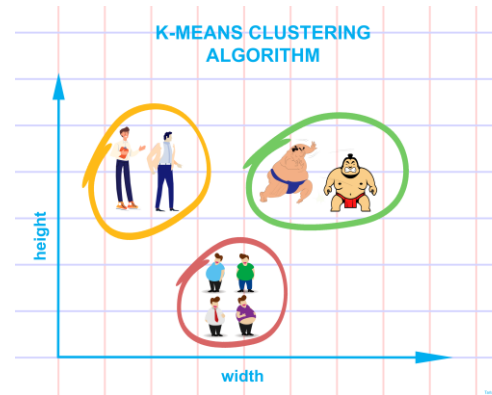

[A Friendly Introduction to K-Means clustering algorithm | by Tarlan Ahadli | Medium](#)

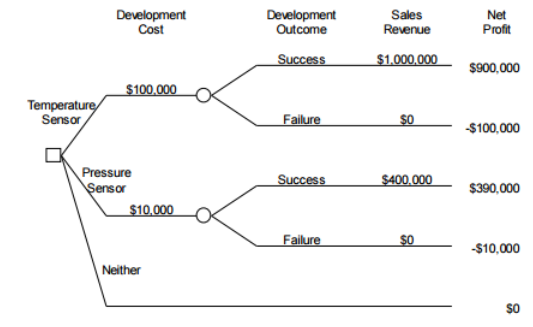
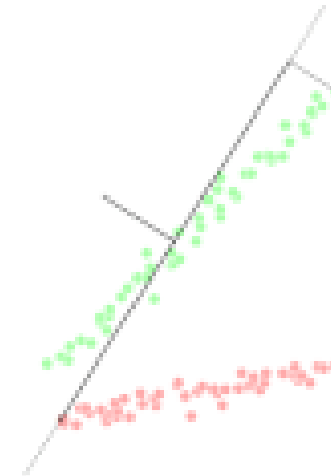

Figure 1.1 Special Instrument Products decision

[Decision Tree: Definition and Examples - Statistics How To](#)

Dimensionality Reduction reduces the number of variables in datasets.

Reducing features aids in enhancing computational efficiency as well as reduces noise.



By Amélia O. F. da S. - Own work, CC BY-SA 4.0,
<https://commons.wikimedia.org/w/index.php?curid=118814421>

Time Series Analysis analyzes data points ordered in time to forecast future trends – think weather forecasting or seasonal electricity usage

Seasonal plot: usmelec

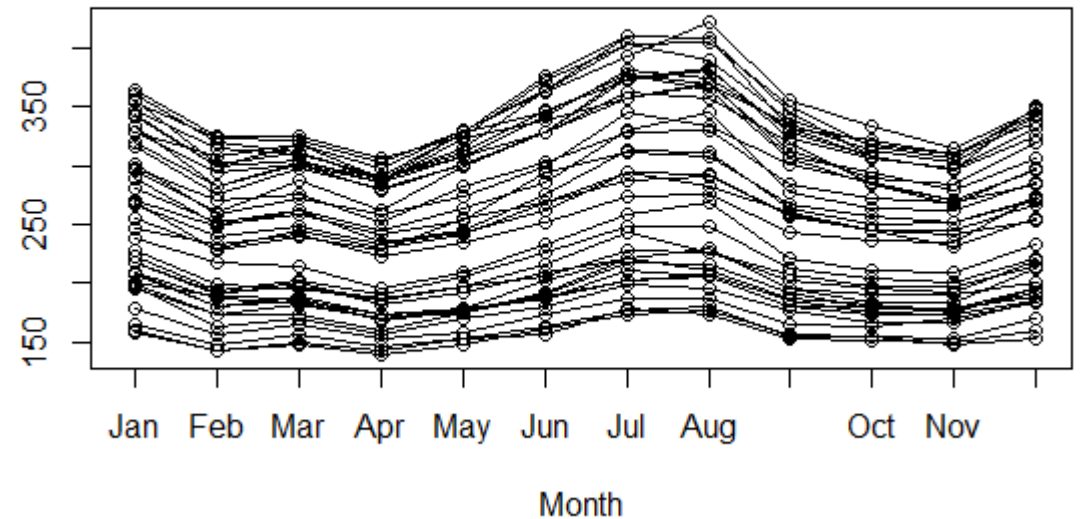

By Daniel Giannini - Own work, CC BY-SA 4.0,
<https://commons.wikimedia.org/w/index.php?curid=40215116>

Markov Chains model sequences of events where each event depends only on the previous event.

Foundational for NLP (natural language processing) and reinforcement learning.

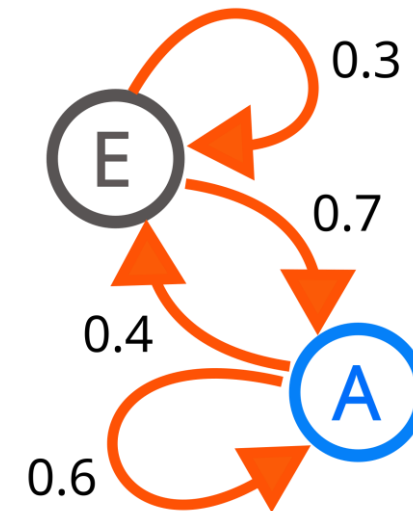

By Joxemai4 - Own work, CC BY-SA 3.0,
<https://commons.wikimedia.org/w/index.php?curid=10284158>

An example of a Markov Chain

Consider a simple weather model with three states:

1. Sunny (S)
2. Cloudy (C)
3. Rainy (R)

A transition matrix for the weather might look like this:

- If it's Sunny, there is a 60% chance it stays Sunny, 30% chance it becomes Cloudy, and 10% chance it rains the next day.
- If it's Cloudy, there is a 40% chance of Sun, 40% chance it stays Cloudy, and 20% chance of Rain.
- If it's Rainy, there's a 20% chance of Sun, 30% chance of Cloudy, and 50% chance it stays Rainy.

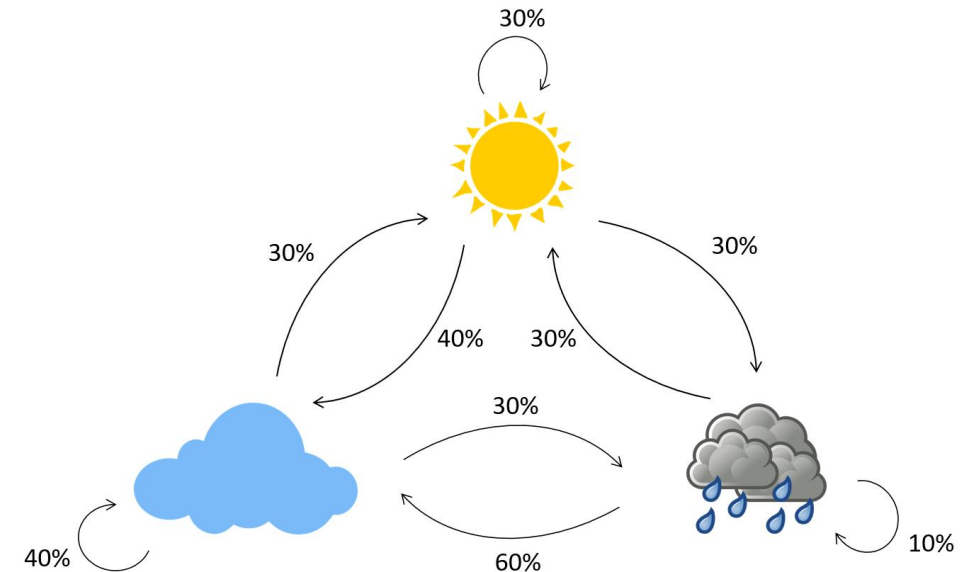

Foundations of AI

Analytics, Data Engineering & Data Science, Machine Learning

The process of analyzing data to discover useful insights, patterns, and trends to help make informed decisions.

- Descriptive – Summarize historic data
- Diagnostic – Understand why something happened by delving deeper into data
- Predictive – Use data, machine learning, and/or statistical techniques to predict future events
- Prescriptive – Recommendations for decision-making by suggesting the best course of action based on data



- Data Engineering
 - Structure, semi-structure, unstructured data
 - Integration, consolidation, cleansing, transformation
 - Operational and analytical data, streaming data, live data
 - Data pipelines, data lakes, data warehouses



Feature	Data Pipeline	Data Lake	Data Warehouse
Purpose	Moves & processes data	Stores raw data	Stores structured, processed data
Data Type	Any type	Raw, unstructured, semi-structured	Structured
Processing	Transforms data	Schema-on-read	Schema-on-write
Use Case	Data movement, ETL/ELT	Big data analytics, ML	Business intelligence, reporting
Storage Format	Temporary or structured	Any format (JSON, CSV, Parquet)	Relational tables (SQL)

How They Work Together

- 1.Data Pipeline** moves data from sources (APIs, IoT, applications) into a **Data Lake**.
- Analysts explore and prepare data from the **Data Lake** for deeper insights.
- 3.Processed & structured data** is transferred from the **Data Lake** to a **Data Warehouse** for BI and reporting.



- Machine Learning is a subset of AI that enables machines to learn from existing data and improve upon this data to make decisions or predictions

- Cloud and Compute
 - CPU, GPU, Quantum



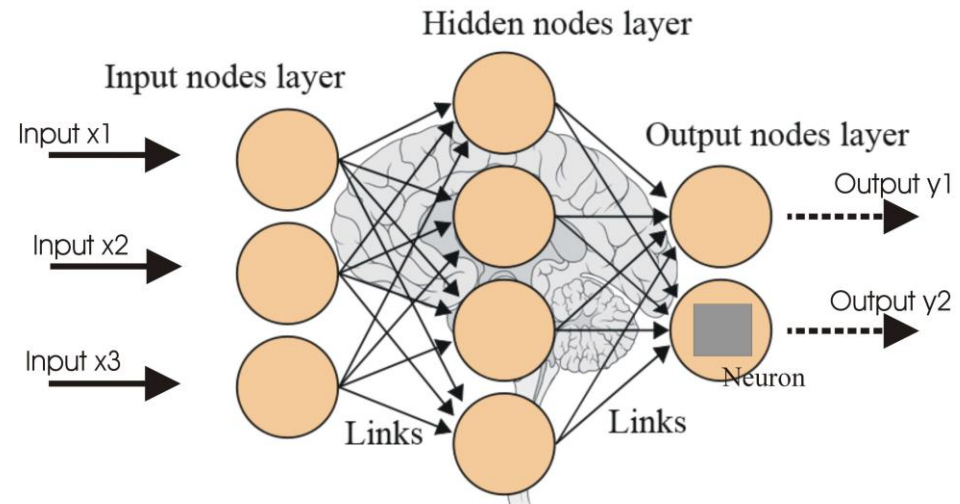
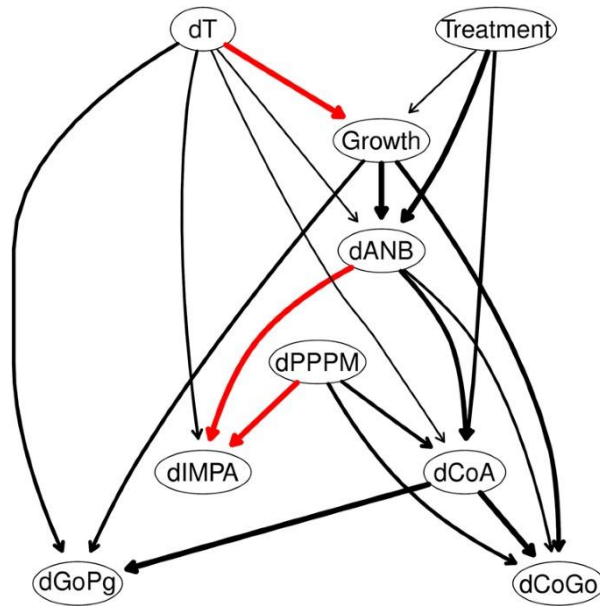

Second Generation AMI and potentially new communication paradigms as LTL data becomes less and less expensive and reaches larger and larger areas – without new infrastructure and by starting to integrate machine learning and AI.

- Research in Power Line Carrier Technology may provide expanded bandwidth to allow for greater data transfer more frequently without as much new infrastructure
- Mesh networks continue to improve, and AMI 2.0 is anticipating leveraging the infrastructure installed in AMI 1.0
- The ability to use cellular and fiber to fill in holes in an AMI system or handle remote areas

We can receive real-time data to help run our distribution systems more effectively and more efficiently using AMI 2.0 and AI





QUESTIONS AND DISCUSSION

Tom Lawton

President

tom.lawton@tescometering.com



TESCO – The Eastern Specialty Company

Bristol, PA

215.228.0500

This presentation can also be found under Meter Conferences and Schools on the **TESCO** website: tescometering.com