



# ANSI Standards and Recent Updates That Affect Metering



Prepared by Tom Lawton, TESCO

*For Pennsylvania Rural Electric Association (PREA)*

*Tuesday, March 13, 2018*

*12:30 p.m. to 1:30 p.m.*

# ANSI

- American National Standard Institute, Inc.
  - Not a government agency
  - Standards do not have force of Law
  - All compliance is voluntary
  - ANSI doesn't actually generate any standards
  - Each standard is controlled by an industry organization as the “secretariat”
    - For C12 NEMA (National Electrical Manufacturer's Association) is the secretariat
    - Paul Orr has been the NEMA's secretary assigned to C12 for over ten years providing continuity to the process



# ANSI

- American National Standard Institute, Inc.
  - NEMA organizes committees to propose and review standards
  - Standards are republished approximately every 5 years
  - Standards codify consensus approaches in common practice
  - Generally, they do not break new ground or deal in controversial issues
    - This is changing. Can't avoid issues any longer.



# ANSI C12

## ➤ C12 Main Committee

- General makeup has expanded slightly over last few years
- 34 voting members with representation from three groups:
  - 12 - Manufacturers: Meter, Socket, Test Equipment, etc.
  - 13 - Users: Utilities
  - 9 - General Interest: PUC, UL, IEEE, Consultants, etc.
- Meets twice a year in conjunction with EEI/AEIC Meter conference.



# ANSI C12

## ➤ C12 Main Committee

- Has final approval for all activities on any C12 family standard
- Establishes Subcommittees (SC) and Working Groups (WG) to address various standards and issues
- Sub committees and Working Groups also meet twice a year in conjunction with EEI Transmission, Distribution and Metering Conference and also hold regular or ad hoc conference calls throughout the year as members put together drafts and other technical material for consideration at the next face to face meeting.



# ANSI C12

## ➤ C12 Subcommittees

- Various subcommittees have been organized to review specific standards
- This is where the work is really done
- Each operates slightly differently
- Each meets on a schedule of its own choosing
- Most meet at EEI Biannual Transmission, Distribution and Metering Meetings
- Communication WG meets more often and longer
- Various subgroups meet frequently by teleconference



# ANSI C12 – Sub-Committees

<b>Sub-Committee</b>	<b>Standards</b>
C12 SC1	C12.1, C12.4, C12.5, C12.10
C12 SC15	C12.6, C12.7, C12.8, C12.9, C12.11
C12 SC16	C12.20, C12.24
C12 SC17	C12.18, C12.19, C12.21, C12.22, C12.23, C12.26
C12 SC29	C12.29 Standard for Field Testing of Metering Sites
C12 SC31	C12.31 VA Measurement Standard
C12 SC46	C12.46 American National Standard for Electricity Meters - 0.1, 0.2 and 0.5 Accuracy Classes for the Measurement of Active, Apparent and Reactive Power



# ANSI C12 SC 1

## ➤ C12.1– Code for Electricity Metering

- C12.1-2014 published in 2016
- Changes in this Revision
  - Vector diagrams for balanced voltages are defined for common services
  - Various definitions have been updated
  - Bi-directional metering is added and tests updated to include bidirectional measurements
  - Significant changes were made to the temperature rise section based on TRINIWOG tests





# ANSI C12 SC 1

## ➤ C12.1 – Code for Electricity Metering

- Changes in this Revision (continued)
  - Table 1b on maximum errors for reference standards was added
    - Tightened to 0.05% and 0.02%
  - Meter Accuracy Class 0.5 was added to the standard
  - A new column was added to all tables with tighter specs for AC 0.5
  - Section 5 on Standards for New and In Service Performance was completely rewritten
  - Appendix D was rewritten and simplified
  - A new Appendix F was added



# ANSI C12 SC 1

## ➤ C12.1 – Code for Electricity Metering

- Safety
  - Work is under way to move the safety related sections of C12.1 into C12.10
  - C12 is coordinating efforts with UL and its work on Subject 2735
    - UL2735C (Canadian) is about to be balloted
- New topics for next revision
  - Changes to EMC Testing
  - Addition of demand testing
  - Revision of Temperature Rise Test based on additional testing



# ANSI C12 SC 1

## ➤ C12.10 – Physical Aspects of Watthour Meters – Safety Standards

- Published C12.10 – 2011
- New revision in editorial review
  - Will add safety sections from C12.1
  - New safety requirements in development
  - Working with UL to achieve consistency with UL 2735C
  - 10 new meter forms with auxiliary power pins



# ANSI C12 SC 1

## New meter forms with Auxiliary Power

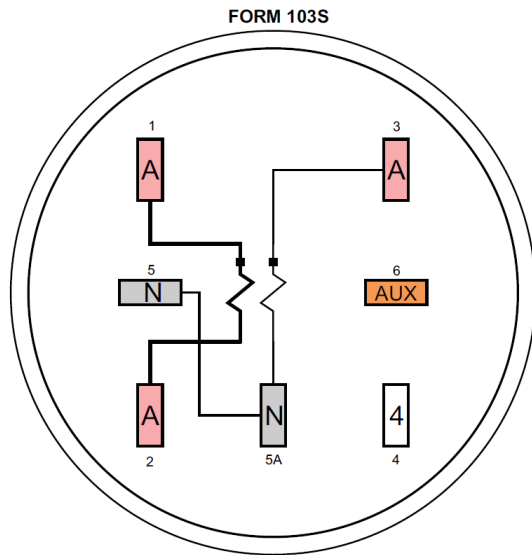

Meter power is between AUX and N.

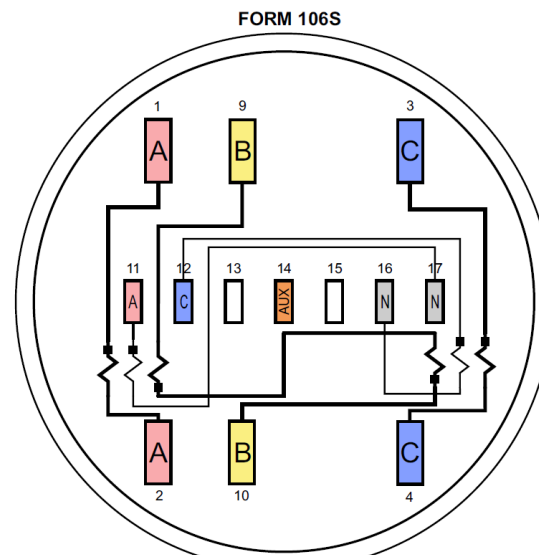

Meter power is between AUX and N.

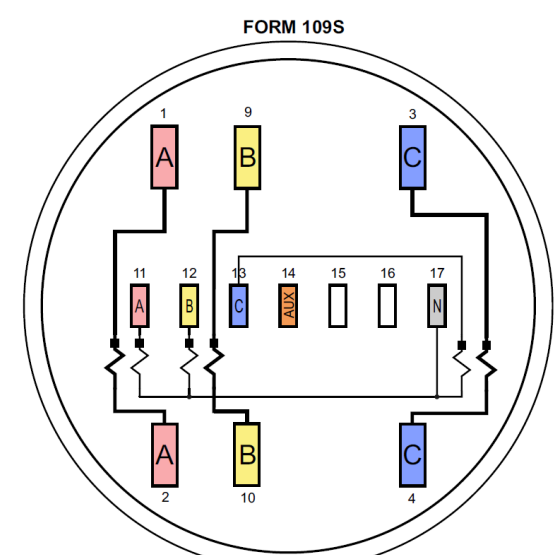

Meter power is between AUX and N.



# ANSI C12 SC 1

## New meter forms with Auxiliary Power

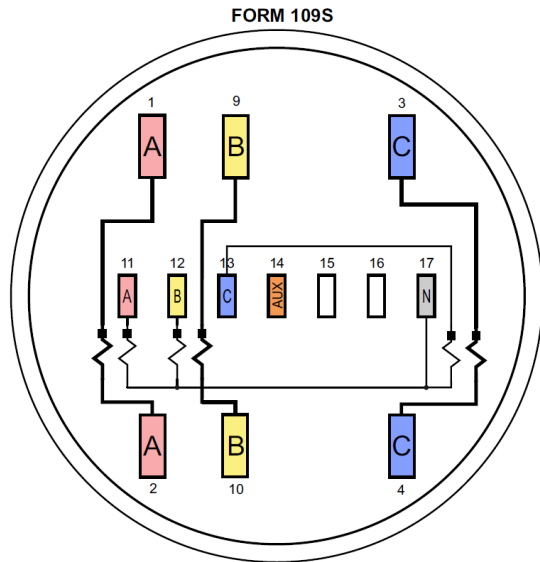

Meter power is between AUX and N.

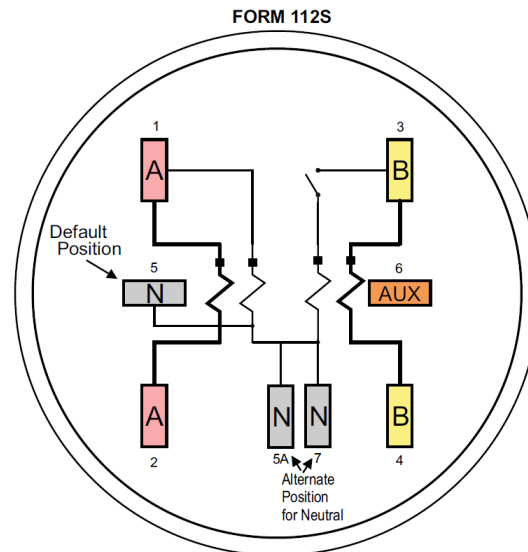

Meter power is between AUX and N.

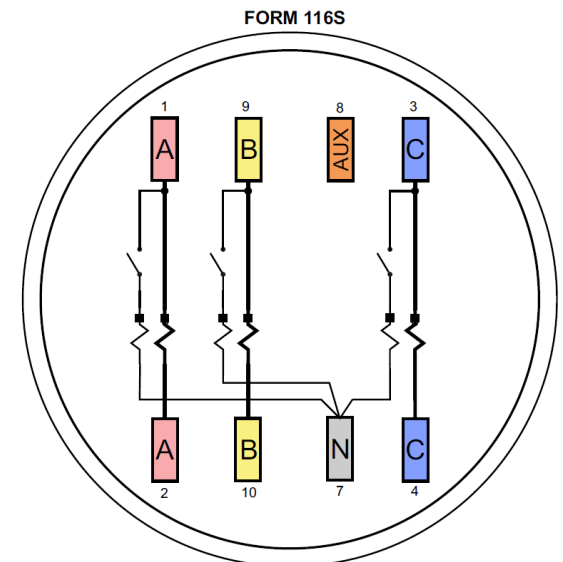

Meter power is between AUX and N.



# ANSI C12 SC 1

## New meter forms with Auxiliary Power

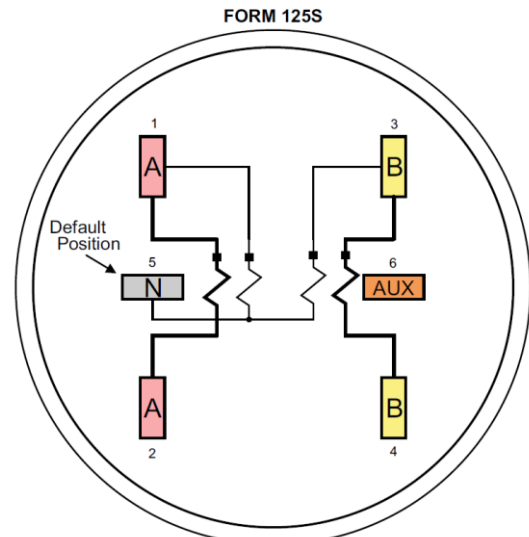

Meter power is between AUX and N.

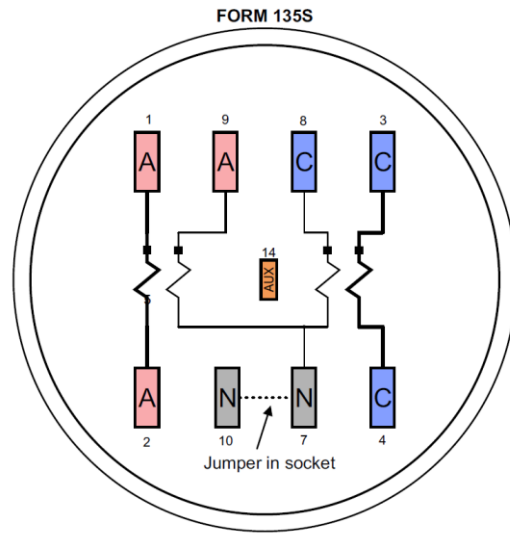

Meter power is between AUX and N.

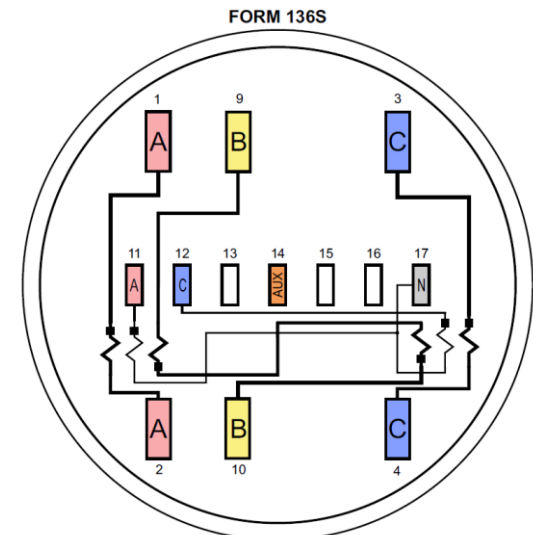

# ANSI C12 SC 1

## New meter forms with Auxiliary Power

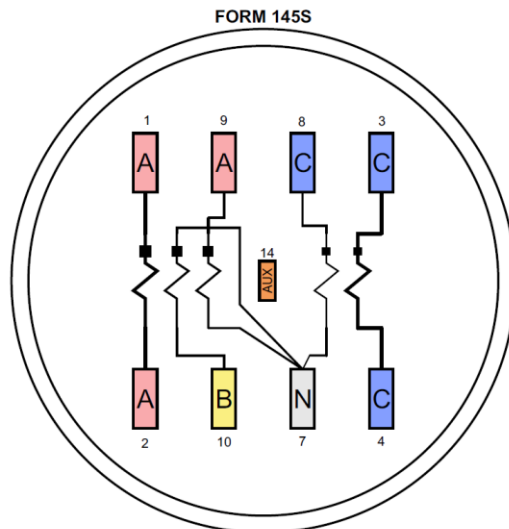

Meter power is between AUX and N.

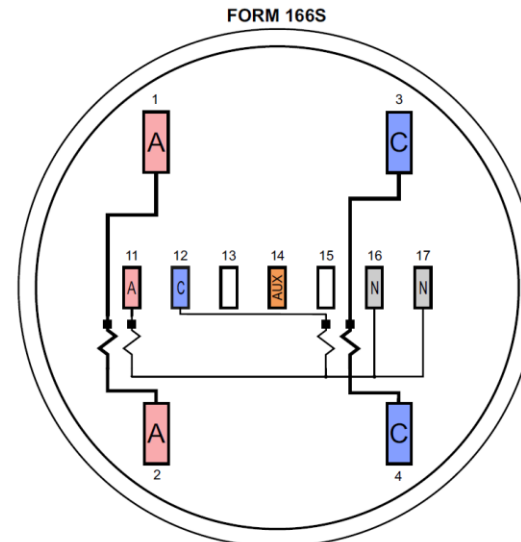

Meter power is between AUX and N.



# ANSI C12 SC 15

- C12.6 – Marking and Arrangement of Terminals for Phase-Shifting Devices used in Metering
  - About to be reissued without change
- C12.7 – Requirements for Watthour Meter Sockets
  - Published – Feb 2015





# ANSI C12 SC 15

- C12.8 – Test Block and Cabinets for Installation of Self contained “A” Base Watthour Meters
  - Published without change Dec 2012
  - Will be deprecated once Figure 4 is moved to C12.7 in its next release



# ANSI C12 SC 15

- C12.9 – Test Switches and Plugs for Transformer Rated Meters
  - Extensive Revision in last publication
  - Specifications for test plugs added
  - Published – March 2015



# ANSI C12 SC 15

- C12.11– Instrument Transformers for Revenue Metering, 10 kBIL through 350 kBIL
  - Revised to parallel C57.13
  - Published – July 2014
  - New proposal on the table to revise barcode formats to allow QR and other more modern codes



# ANSI C12 SC16

- C12.20 – 0.1, 0.2 and 0.5 Accuracy Class Metering
  - C12.20 -2015 Published May 2017, Errata sheet also published
  - 0.1 Percent Accuracy Class Added
    - New column added to all accuracy test tables
  - Section 4.6 added to provide specifications for test outputs
    - Type B port specifications were made “informative” due to a lack of unanimity. No Standard can force a manufacturer or utility to change their existing practices without their voluntary consent.



# ANSI C12 SC16

- C12.20 – 0.1, 0.2 and 0.5 Accuracy Class Metering
  - Tighter performance at reference conditions was specified
  - Table 2 updated to make clear which forms and applications are Blondel compliant.
  - Table 2A added to make clear which forms and applications are NOT Blondel compliant
    - Therefore NOT covered by the standard



# ANSI C12 SC16

- C12.20 – 0.1, 0.2 and 0.5 Accuracy Class Metering
  - Polyphase loading for accuracy testing is allowed and details provided
    - In next revision polyphase loading is proposed to be **REQUIRED**
  - Non-Sinusoidal Performance Testing
    - Harmonics WG
      - Extensive performance testing using non-sinusoidal waveforms was added



# ANSI C12 SC16

- C12.20 – 0.1, 0.2 and 0.5 Accuracy Class Metering
  - Areas of activity for next revision
    - Auxiliary device influences (requiring accuracy testing with any communication devices active)
    - Disturbances test for memory corruption due to rapid power cycling such as during dropout/reclosure events
    - Extended temperature operating ranges



# ANSI C12 SC29

## Field Testing of Metering Installations

- Field Testing of Metering Accuracy
  - Hope to send for approval after next meeting
  - Agreement on single set of acceptability criteria for testing under all three modes
    - Voltage and current supplied by test equipment
    - Site voltage, equipment provided current
    - Site voltage and current (customer load)
  - Final issue is review of “acceptability” values





# ANSI C12 SC31

## VA and VAR Metering Standard

- Establish a legal definition for VA and VAR
- VA being addressed first in order to “Fast Track” the result.
  - Definitions agreed upon
  - Initial draft completed
- At this meeting, new quantity “source VA” was proposed by Landis+Gyr
  - Committee agreed to consider during a series of WEB conferences
- Goal is to promote VA and active energy (watts) as the primary metering quantities.



# ANSI C12.46

- Sub-Committee to Develop a Replacement for C12.1 and C12.20
  - Adopts the structure of OIML IR-46
  - Addresses 0.1, 0.2, and 0.5 Accuracy Classes
  - Addresses Active, Reactive, and Apparent Energy
  - Will be biggest change to metering standards in 100 years
  - Review and editing of draft in process
  - Expected Publication 2020



# Questions and Discussion



Tom Lawton

TESCO – The Eastern Specialty Company

Bristol, PA

215-688-0298(cell)

215-785-2338 (office)

Tom.Lawton@tescometering.com

This presentation can also be found under Meter Conferences  
and Schools on the TESCO website:

[www.tescometering.com](http://www.tescometering.com)

