



Test Switch Operation, Specification & Accessories

Notes from the Field
Prepared by Tom Lawton, TESCO



**NORTH CAROLINA
ELECTRIC METER SCHOOL
AND CONFERENCE**

06/23/2013 - 06/27/2013
Embassy Suites @ Kingston Plantation
Myrtle Beach, South Carolina

for the NC Electric Meter School 2013

Agenda

- Introduction
- Using Test Switches
- Meter Test Switch Specifications
- Meter Test Switch Configurations
- Meter Test Switch Accessories
- Pre-Wired Transformer Rated Enclosures



**NORTH CAROLINA
ELECTRIC METER SCHOOL
AND CONFERENCE**

06/23/2013 - 06/27/2013
Embassy Suites @ Kingston Plantation
Myrtle Beach, South Carolina

Typical Self Contained Service

- Typically found in residential metering
- Meters are capable of handling the direct incoming amperage
- Meter is connected directly to the load being measured
- Meter is part of the circuit
- When the meter is removed from the socket, power to the customer is interrupted

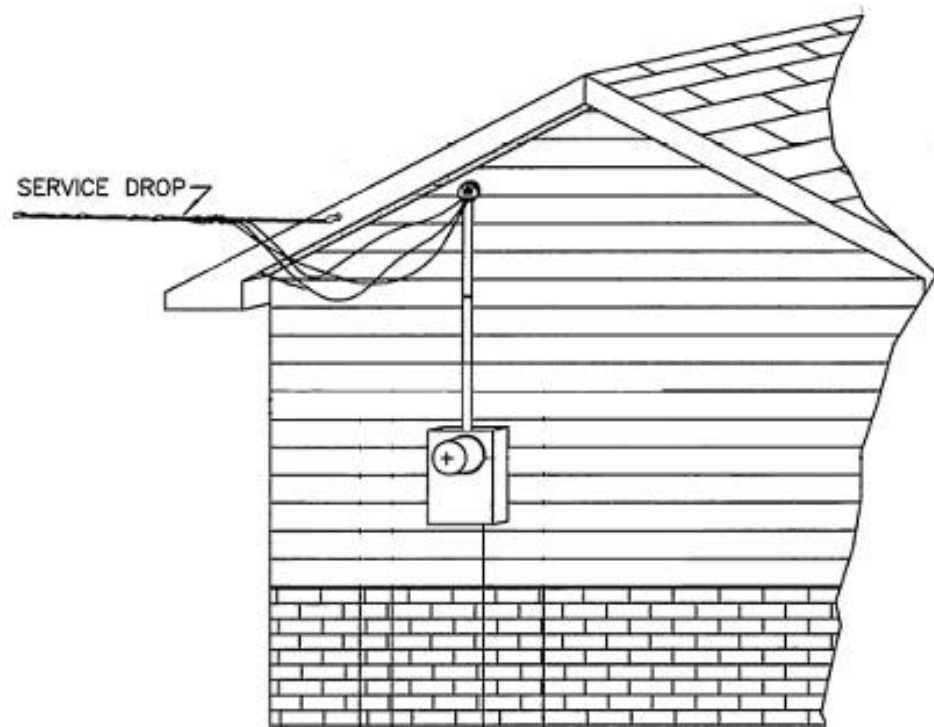

**NORTH CAROLINA
ELECTRIC METER SCHOOL
AND CONFERENCE**

06/23/2013 - 06/27/2013
Embassy Suites @ Kingston Plantation
Myrtle Beach, South Carolina

Transformer Rated Service

- Meter measures scaled down representation of the load.
- Scaling is accomplished by the use of external current transformers (CTs) and sometimes voltage transformers or PTs).
- The meter is NOT part of the circuit
- When the meter is removed from the socket, power to the customer is not effected.

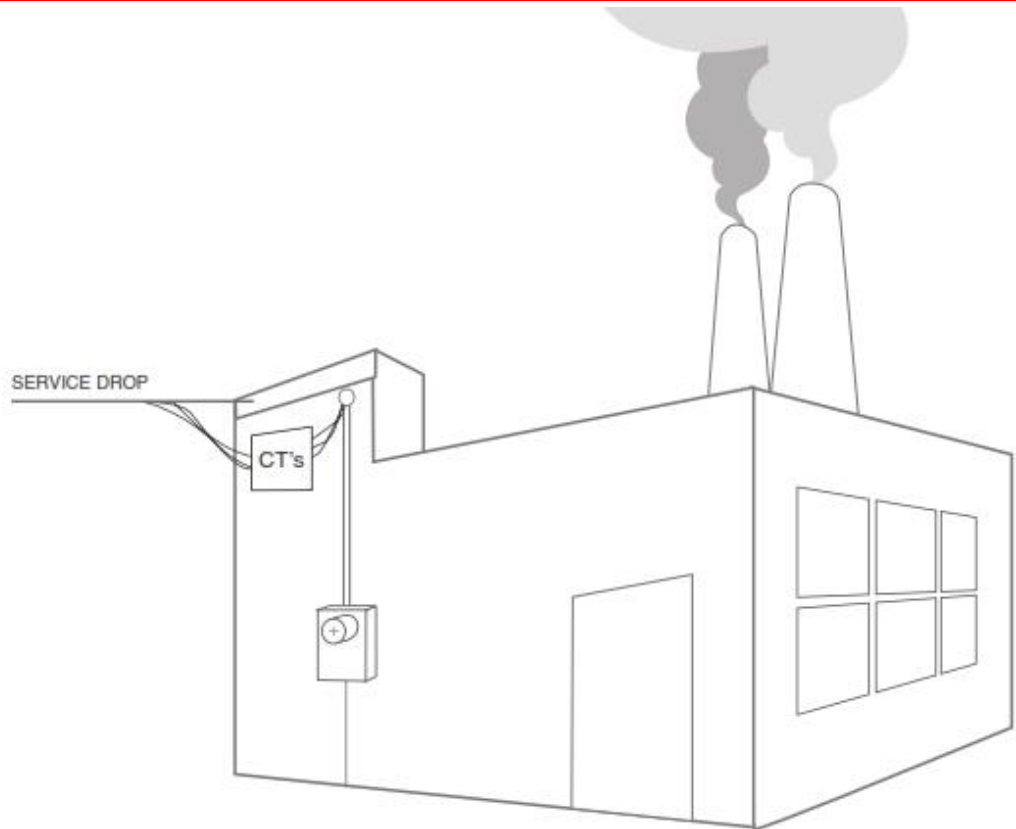

**NORTH CAROLINA
ELECTRIC METER SCHOOL
AND CONFERENCE**

06/23/2013 - 06/27/2013
Embassy Suites @ Kingston Plantation
Myrtle Beach, South Carolina

Test Switch Safety

Testing current transformers while they are in service can be a dangerous operation if certain safety procedures are not followed. The secondary loop of a current transformer must **NEVER BE OPENED** when service current is present in the primary. When there is current in the primary, and the secondary of a current transformer is open circuited, the voltage across the secondary can rise to hundreds and even thousands of volts, creating an extremely dangerous situation. The open CT secondary voltage magnitude varies with CT design and primary current flow. The high voltage that is present on the open secondary of an energized current transformer generates two great hazards. The first hazard is **ELECTRICAL SHOCK TO TESTING PERSONNEL**. The second hazard is **THE BREAKDOWN OF THE CURRENT TRANSFORMER INSULATION**. Both hazards can be avoided provided that the secondary of the current transformer is never opened. The safest current transformer installations for testing are those that have a Test Switch as part of the secondary loop. A Test Switch is a device that will facilitate inserting instrumentation in the current transformer secondary loop without the danger of opening the circuit.



**NORTH CAROLINA
ELECTRIC METER SCHOOL
AND CONFERENCE**

06/23/2013 - 06/27/2013
Embassy Suites @ Kingston Plantation
Myrtle Beach, South Carolina

Meter Test Switch Specifications



- ANSI C12 Definitions
- Test Switch Materials
- Plating
- Barriers
- Wiring Connections
- What to look for
- Covers



**NORTH CAROLINA
ELECTRIC METER SCHOOL
AND CONFERENCE**

06/23/2013 - 06/27/2013
Embassy Suites @ Kingston Plantation
Myrtle Beach, South Carolina

ANSI C12.9 Test Switch Definitions

AMERICAN NATIONAL STANDARD

ANSI C12.9-2011

For Test Switches and Jacks for Transformer-Rated Meters

1 Scope

This standard is intended to encompass the dimensions and functions of meter test switches used with transformer-rated watt-hour meters in conjunction with instrument transformers and test plugs used in conjunction with the test switch.

2 Definitions

2.1 short-circuiting switch

A single-pole double-throw (make-before-break) transfer switch used to transfer current away from the meter.

2.2 test jack

A spring-jaw receptacle in the current element of a test switch that provides a bipolar test connection in the metering current circuit without interruption of the current circuit.

2.3 test jack switch

A single-pole single-throw disconnect switch used in conjunction with a test jack to provide a parallel current path during normal operating conditions.

2.4 test plug

A bipolar mating plug to a test jack for inserting instrumentation into the metering current circuit.

2.5 voltage switch

A single-pole single-throw switch used to open or close a voltage circuit.

3 Standard ratings

3.1 Current

The current rating shall be 20 A minimum.

3.2 Voltage

The voltage rating shall be 300 V or 600 V.

4 General requirements for test switches

4.1 Material and workmanship

The test switch and its components shall be substantially constructed of suitable material in a workmanlike manner.

4.2 Nameplates

Nameplates are not required on these test switches, but a manufacturer's identifying marking (such as catalog number, trademark, etc.) shall be stamped, printed, affixed, or cast in a convenient place on each test switch. When required, a warning label indicating hidden internal jumpers should be affixed.

4.3 Movable parts

Movable conducting parts such as blade hinges shall be held in place by locknuts or pins or their equivalent, arranged so that a firm and secure connection will be maintained at any position of the switch blade.



**NORTH CAROLINA
ELECTRIC METER SCHOOL
AND CONFERENCE**

06/23/2013 - 06/27/2013
Embassy Suites @ Kingston Plantation
Myrtle Beach, South Carolina

ANSI C12.9 Test Switches

FOR TRANSFORMER-RATED METERS

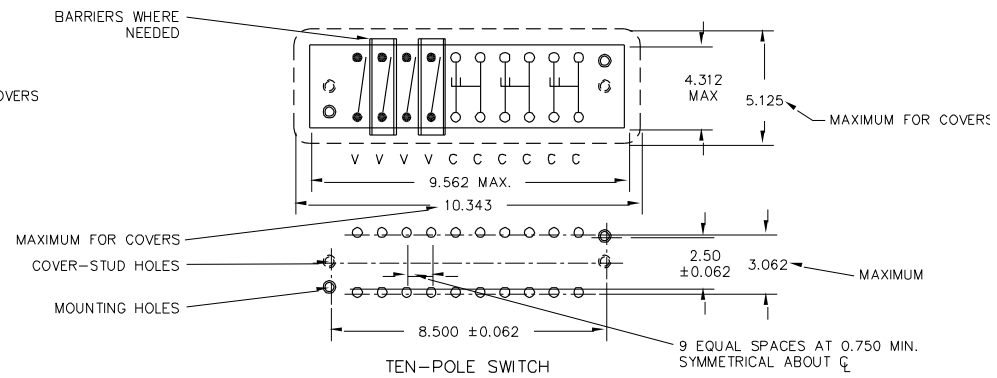
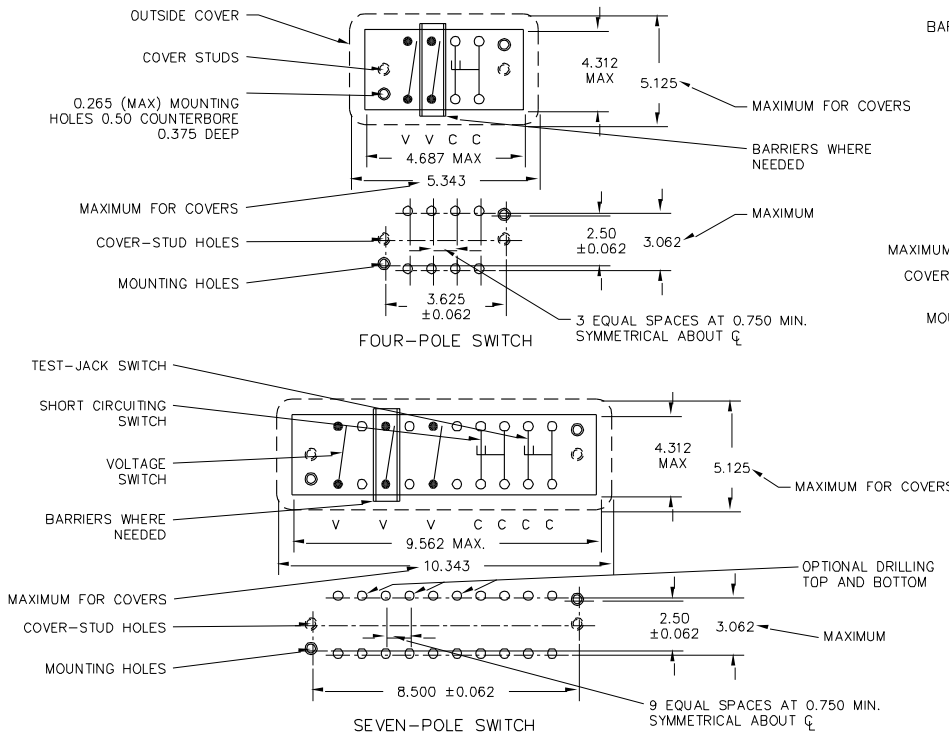

NOTES: (1) All dimensions are in inches.

(2) Unless otherwise specified, all tolerance shall be ± 0.015 inch.



**NORTH CAROLINA
ELECTRIC METER SCHOOL
AND CONFERENCE**

06/23/2013 - 06/27/2013
Embassy Suites @ Kingston Plantation
Myrtle Beach, South Carolina

ANSI C12.9 Test Switches

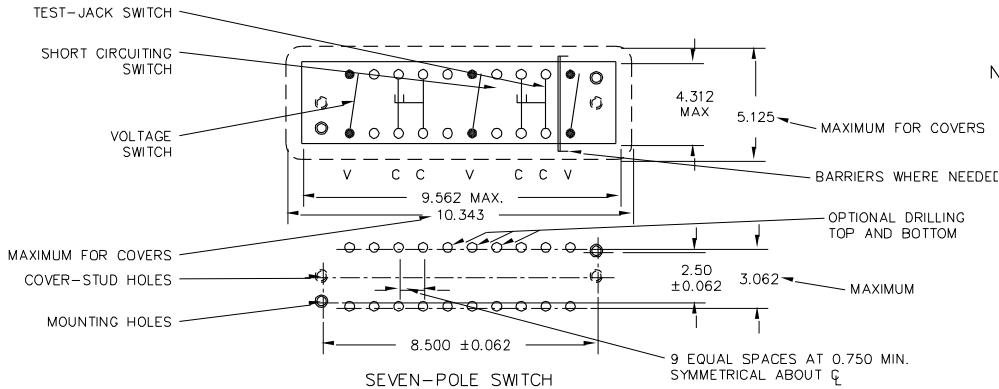
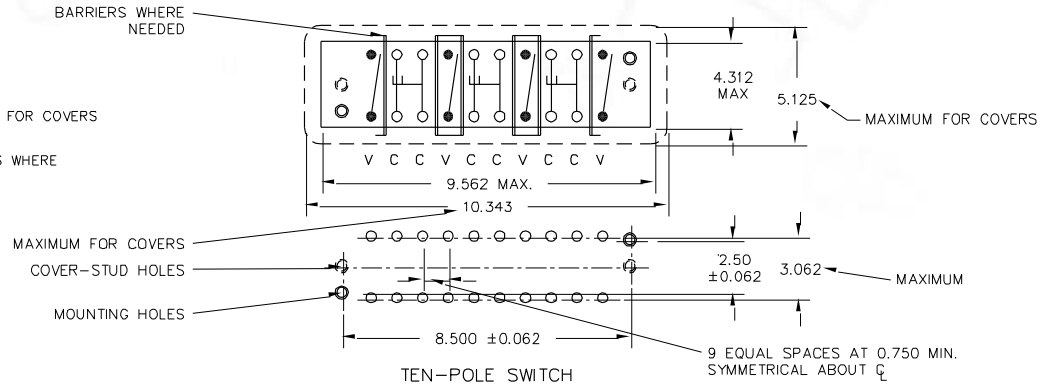
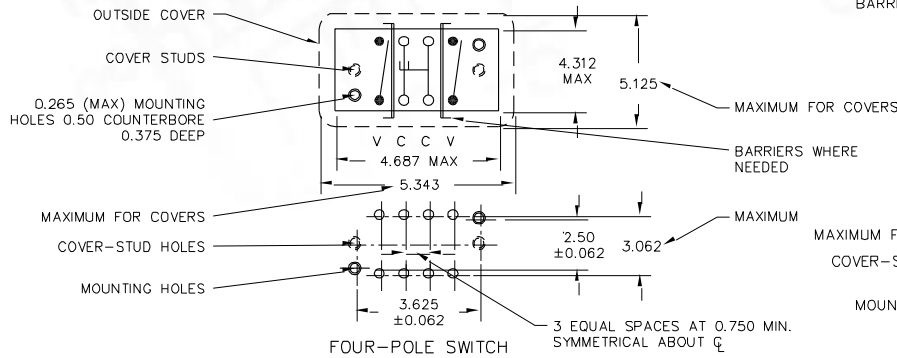

NOTES: (1) All dimensions are in inches.
(2) Unless otherwise specified, all tolerance shall be ± 0.015 inch.



**NORTH CAROLINA
ELECTRIC METER SCHOOL
AND CONFERENCE**

06/23/2013 - 06/27/2013
Embassy Suites @ Kingston Plantation
Myrtle Beach, South Carolina

ANSI C12.9 General Test Switch Specifications

1.1 Insulating barriers

When a voltage switch is installed adjacent to current switch or to another voltage switch at a different potential then for safety considerations the two switches shall be separated by an insulating barrier as indicated in figures 1 through 3. Barriers may be an integral part of the base, a separate part fastened to the base, or an integral part of each individual switch section.

1.2 Wiring terminals and test clips

1.2.1 Wiring terminals

Test switches shall be provided with suitable wiring terminals for the connection of AWG No. 14 to AWG No. 8 secondary conductors.

1.2.2 Test clips

Facilities for attaching test clips shall be provided on the terminals or on the wire binding screws.

1.3 Mounting holes

Mounting holes (two minimum) shall be of the dimensions shown in figures 1 through 3.

1.4 Cover

1.4.1 General

An insulated cover shall be available for the test switches and if used shall be held in place by cover studs. The cover may be made of glass, plastic or other suitable non-conducting material, but shall not exceed the maximum dimensions shown in figures 1 through 3. When the cover is in place, all switches shall be in a closed position.

1.4.2 Cover holes

The diameter of the cover-stud holes shall be 0.281 in., located as shown in figures 1 through 3.

1.4.3 Cover studs

Removable cover studs with suitable provisions for sealing shall be available for use in each instrument-transformer-meter test switch in the positions indicated in figures 1 through 3. The diameter of these studs shall not exceed 0.25 in. Standard instrument-transformer-meter test switches shall be provided either with or without cover studs.

1.5 Acceptable spacings

The minimum acceptable spacings shall be as indicated in table 2.

Table 2 – Minimum acceptable spacings

Voltage between parts involved (V)	Minimum spacings from live parts to			
	Parts of opposite polarity*		Grounded metal**	
	Over surface (in.)	Through air (in.)	Over surface (in.)	Through air (in.)
0-300***	0.750*	0.375*	0.500	0.375
301-600	1.250*	0.750	1.000	0.500

*To be acceptable at other than wiring terminals, through-air and over-surface spacings of 0.375 in between parts of opposite polarity shall withstand a special dielectric strength test at 6 000 V, 60 Hz, for 1 min.

**To be acceptable at other than wiring terminals, through-air and over-surface spacings of 0.375 in between current-carrying parts and cast-metal enclosure or grounded metal, where indentation or deformation of the overall enclosure will not affect spacings, shall withstand a special dielectric strength test at 6 000 V, 60 Hz, for 1 min.

***300 V spacings apply to a 600 V test switch, if the phase-to-neutral voltage does not exceed 300 V for spacings: (1) from neutral to phase-voltage parts, and (2) from neutral to grounded metal.



**NORTH CAROLINA
ELECTRIC METER SCHOOL
AND CONFERENCE**

06/23/2013 - 06/27/2013
Embassy Suites @ Kingston Plantation
Myrtle Beach, South Carolina

Meter Test Switch Configurations

- Layout
- Handle Colors
- Reversed vs. Normal Potentials
- Current Links
- Base Sizing
- Barrier Locations

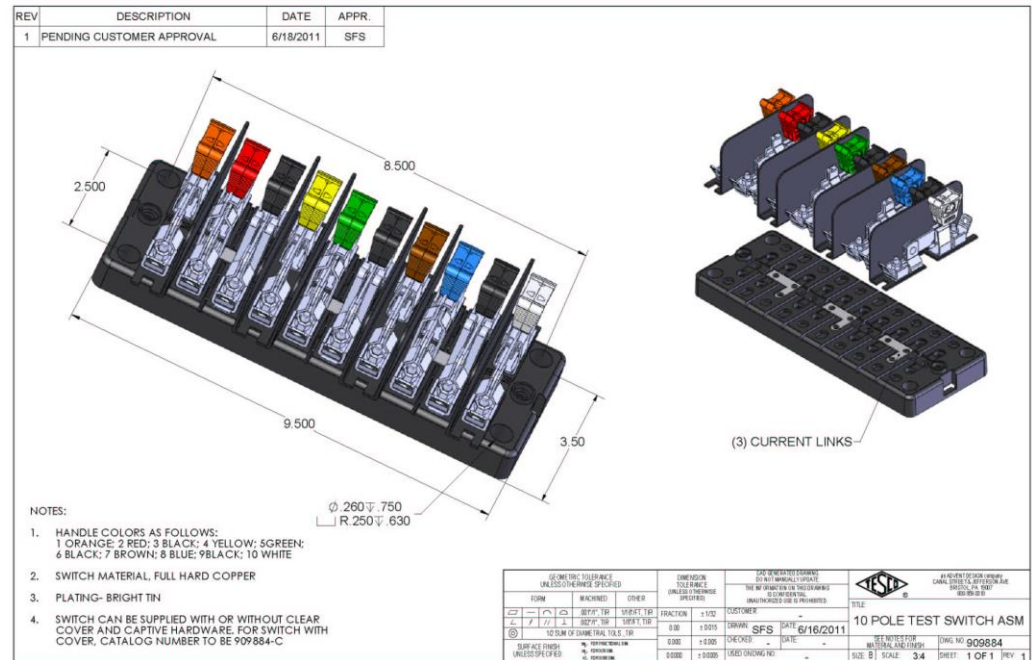

**NORTH CAROLINA
ELECTRIC METER SCHOOL
AND CONFERENCE**

06/23/2013 - 06/27/2013
Embassy Suites @ Kingston Plantation
Myrtle Beach, South Carolina

Meter Test Switch Accessories

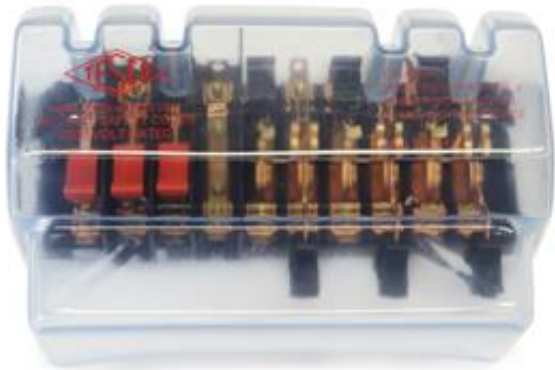

- Test Plugs
- Safety Covers
- Test Switch Isolators

NOTE: On installations that contain Test Switches, test leads terminated with a test switch safety test probe (test plug) should be used for CT testing. This provides a “make-before-break” connection to prevent accidental opening of the current transformer secondary loop.



**NORTH CAROLINA
ELECTRIC METER SCHOOL
AND CONFERENCE**

06/23/2013 - 06/27/2013
Embassy Suites @ Kingston Plantation
Myrtle Beach, South Carolina

ANSI C12.9 Test Jack Specifications

4.6 Provision for test plugs

Each double-pole short-circuiting current switch shall incorporate a test jack which is designed to permit the insertion of a test plug. The test-jack switch can be either in the left-hand or the right-hand position. In order to assure proper mating with the test plug the test jack shall conform to Figure 4.

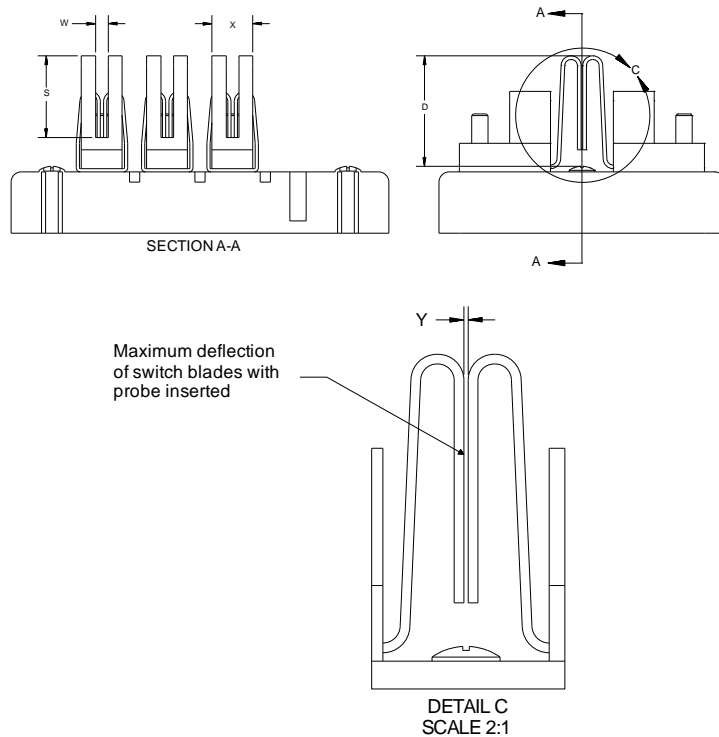

Figure 4 – Test switch typical cross section

Table 1 – Test switch dimensions

TEST SWITCH DIMENSIONS			
DIMENSION	MINIMUM	PREFERRED	MAXIMUM
S	0.900	1.200	1.250
W	0.125	0.140	0.175
X	0.430	0.500	0.550
D	1.280	1.350	N/A
Y			0.188



**NORTH CAROLINA
ELECTRIC METER SCHOOL
AND CONFERENCE**

06/23/2013 - 06/27/2013
Embassy Suites @ Kingston Plantation
Myrtle Beach, South Carolina

ANSI C12.9 Test Plug Specifications

1 General requirements for test plugs

1.1 Materials and workmanship

The test plug shall be constructed with an insulated handle providing an anti-slip gripping area and a barrier to help prevent the user's gloved hand from slipping into contact with the test switch.

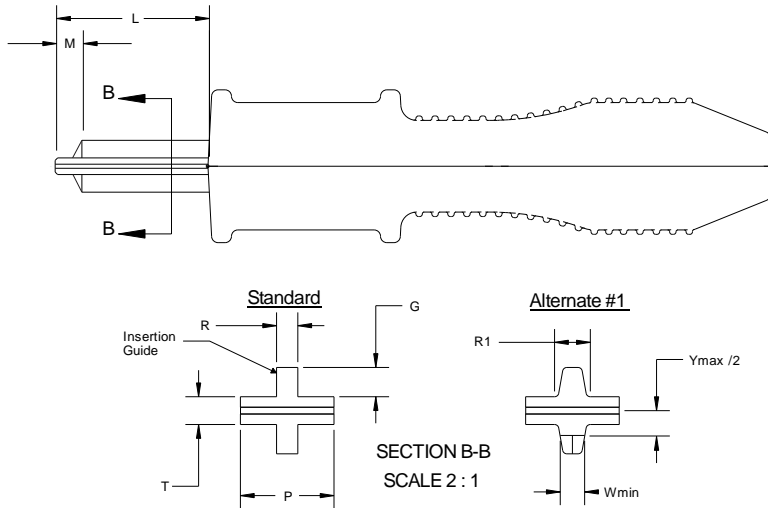

Figure 6 – Typical test plug

Notes:

- (1) When the insertion guide takes the form of Section B-B Alternate #1, then for a switch with a slot width W_{min} , the switch Jaws shall not be separated by more than $Y_{max} = 0.188''$ when inserted.
- (2) If a positive stop is provided on the probe blade to limit insertion depth of the probe to M by bottoming out against S of the switch, then L may exceed L_{max} provided $M < D_{min} - S_{max} = 0.030''$.

Table 3 – Test plug dimensions

TEST PLUG DIMENSIONS			
DIMENSION	MINIMUM	PREFERRED	MAXIMUM
L	1.100	1.200	1.260
M	0	0.140	0.175
R	0.090	0.110	0.120
R1	n/a	n/a	0.156
T	0.100	0.130	0.156
G	0.040	0.125	0.175

ALERT TO USERS: Prior to adoption of this standard there are known instances of probes and switches where interferences exist which may not allow all probes and switches to mate or which may lead to probes shorting to undesired conductors.



**NORTH CAROLINA
ELECTRIC METER SCHOOL
AND CONFERENCE**

06/23/2013 - 06/27/2013
Embassy Suites @ Kingston Plantation
Myrtle Beach, South Carolina

Pre-Wired Transformer Rated Enclosures

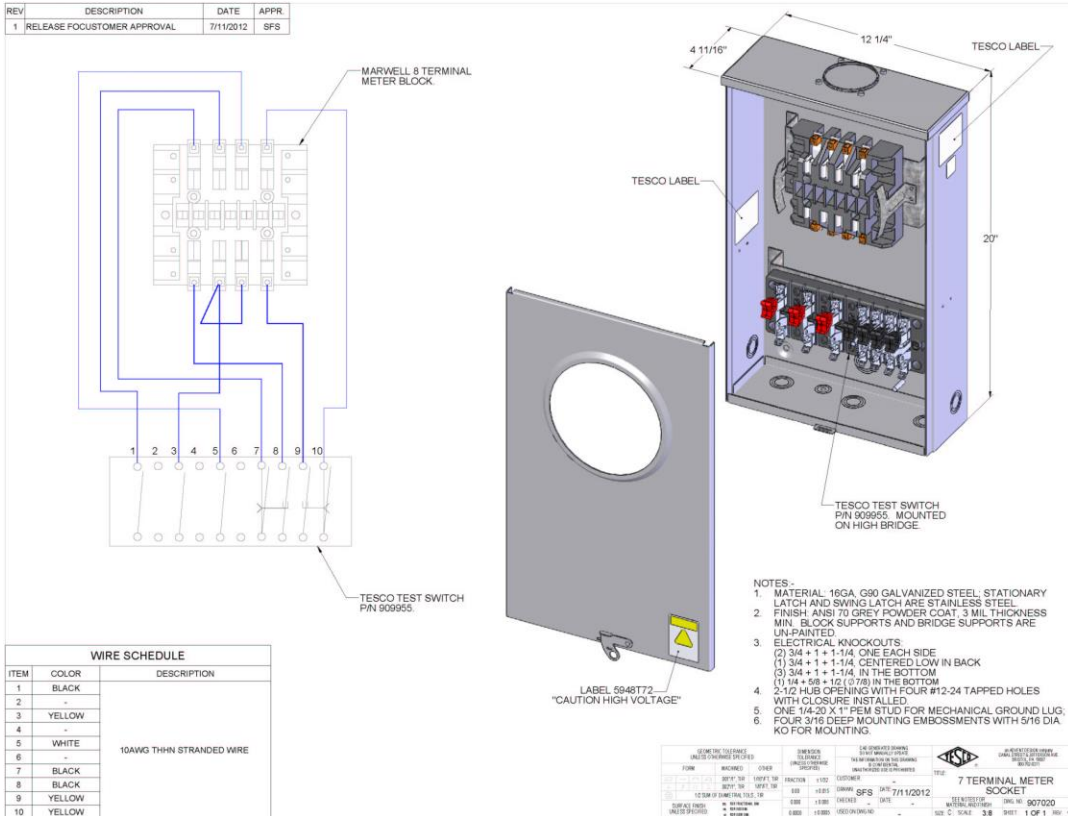

- Cover Types
- Wiring
- Sockets

**NORTH CAROLINA
ELECTRIC METER SCHOOL
AND CONFERENCE**

06/23/2013 - 06/27/2013
Embassy Suites @ Kingston Plantation
Myrtle Beach, South Carolina

Questions and Discussion



Tom Lawton

TESCO – The Eastern Specialty Company

Bristol, PA

1-800-762-8211

This presentation can also be found under Meter
Conferences and Schools on the TESCO web site:

www.tesco-advent.com



**NORTH CAROLINA
ELECTRIC METER SCHOOL
AND CONFERENCE**

06/23/2013 - 06/27/2013
Embassy Suites @ Kingston Plantation
Myrtle Beach, South Carolina