



THE EASTERN SPECIALTY COMPANY



Georgia Power

Instrument Transformer Testing in the Shop and Field

Tom Lawton, TESCO



CARIBBEAN METER SCHOOL

JANUARY 30, 2019

ATLANTA, GA

OBJECTIVE – UNDERSTAND THE NEED AND BEST PRACTICES FOR INSTRUMENT TRANSFORMER TESTING IN AN AMI WORLD

- Instrument Transformer Testing (in shop and in field)
- Why do we test?
- How do we test?
- What range of tests/checks should be done in the shop?
- What range of tests/checks should be done in the field?
- Where is the biggest pay back for our limited meter service resources (field and shop)?

WHY DO WE TEST?

- Our regulatory commissions require us to test meters.
- But only for accuracy. State regulatory commissions want electric utilities to ensure that no customer is being billed unfairly and that no subset of customers is being unfairly subsidized by the rest of the rate payers. Some states mandate only accuracy tests and others require demand and time of use accuracy tests.
- Any tests beyond accuracy tests are tests that are simply good business practice.
- No tests are mandated for functional or accuracy testing of the instrument transformers that are an integral part of the metering circuit.

WHY?

**Because the Transformer
Rated Services are where the
money is!!!!**

THE IMPORTANCE OF CT TESTING IN THE FIELD

- One transformer in three wired backwards will give the customer a bill of $\frac{1}{3}$ rd the actual bill.
- One broken wire to a single transformer will give the customer a bill of $\frac{2}{3}$ rd the actual bill
- One dual ratio transformer inappropriately marked in the billing system as 400:5 instead of 800:5 provides a bill that is $\frac{1}{2}$ of the actual bill. And the inverse will give a bill double of what should have been sent. Both are lose-lose situations for the utility.



THE IMPORTANCE OF CT TESTING IN THE FIELD (CONT)

- Cross Phasing (wiring errors)
- Loose or Corroded Connections
- CT Mounted Backwards
- CT's with Shorted Turns
- Wrong Selection of Dual Ratio CT
- Detect Magnetized CT's
- Burden Failure in Secondary Circuit
- Open or Shorted Secondary
- Mislabeled CT's
- Ensures all Shorting Blocks have been Removed

TESTING AT TRANSFORMER RATED SITES

- ✓ Meter Accuracy
- ✓ Full Load
- ✓ Light Load
- ✓ Power Factor
- ✓ CT Health
- ✓ Burden Testing
- ✓ Ratio Testing
- ✓ Admittance Testing
- ✓ Site Verification



PROPERLY SIZING CONVENTIONAL AND EXTENDED RANGE CT'S

- CT Ratings/Parameters
- Standard Accuracy Classes
- Extended-Range Ratings/Types
- Applying ERCTs
- Advantages of ERCT
- The historic revenue metering class is 0.3, with 0.15 being used with increasing frequency.
- 0.15 “high accuracy” classes were introduced under IEEE C57.13.6.



FUNDAMENTALS OF POLYPHASE FIELD METER TESTING AND SITE VERIFICATION

Functionality with Burden Present on the Secondary Loop

PHASE A

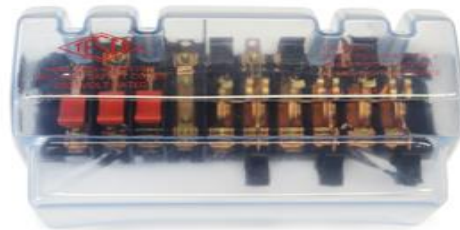

- Some burden will always be present – junctions, meter coils, test switches, cables, etc.
- CT's must be able to maintain an accurate ratio with burden on the secondary.

METERING ACCURACY RATING

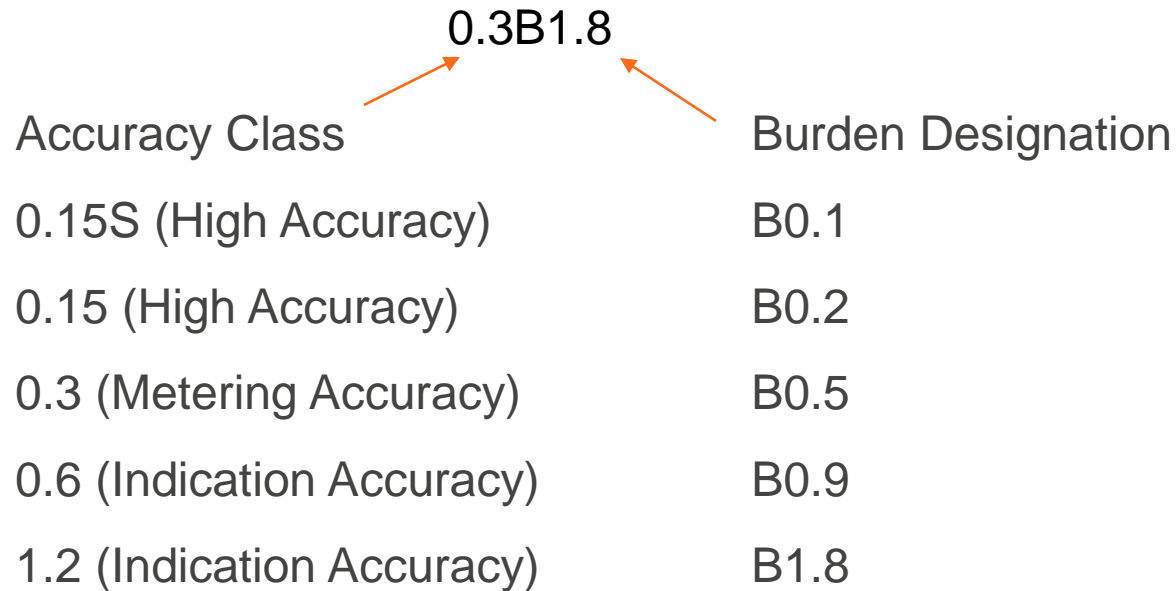

Fundamentals of Polyphase Field Meter Testing and Site Verification

Functionality with Burden Present on the Secondary Loop

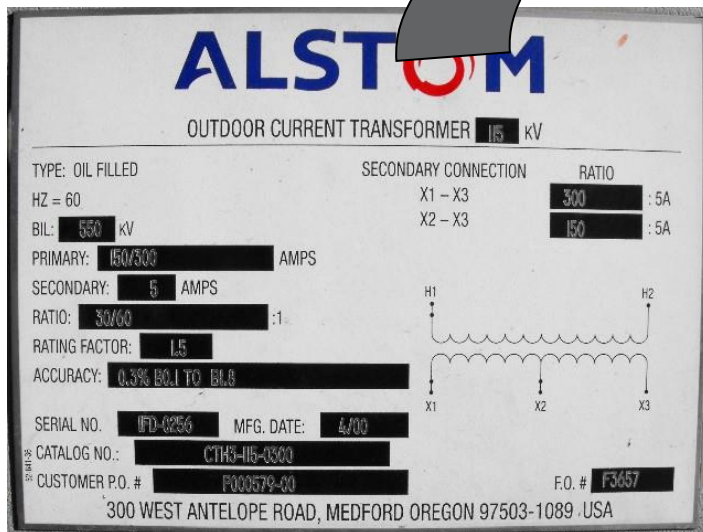

Example Burden Spec:
0.3% @ B0.1, B0.2, B0.5
or

There should be less than the 0.3% change in secondary current from initial ("0" burden) reading, when up to 0.5 Ohms of burden is applied

CURRENT TRANSFORMER ACCURACY CLASSES

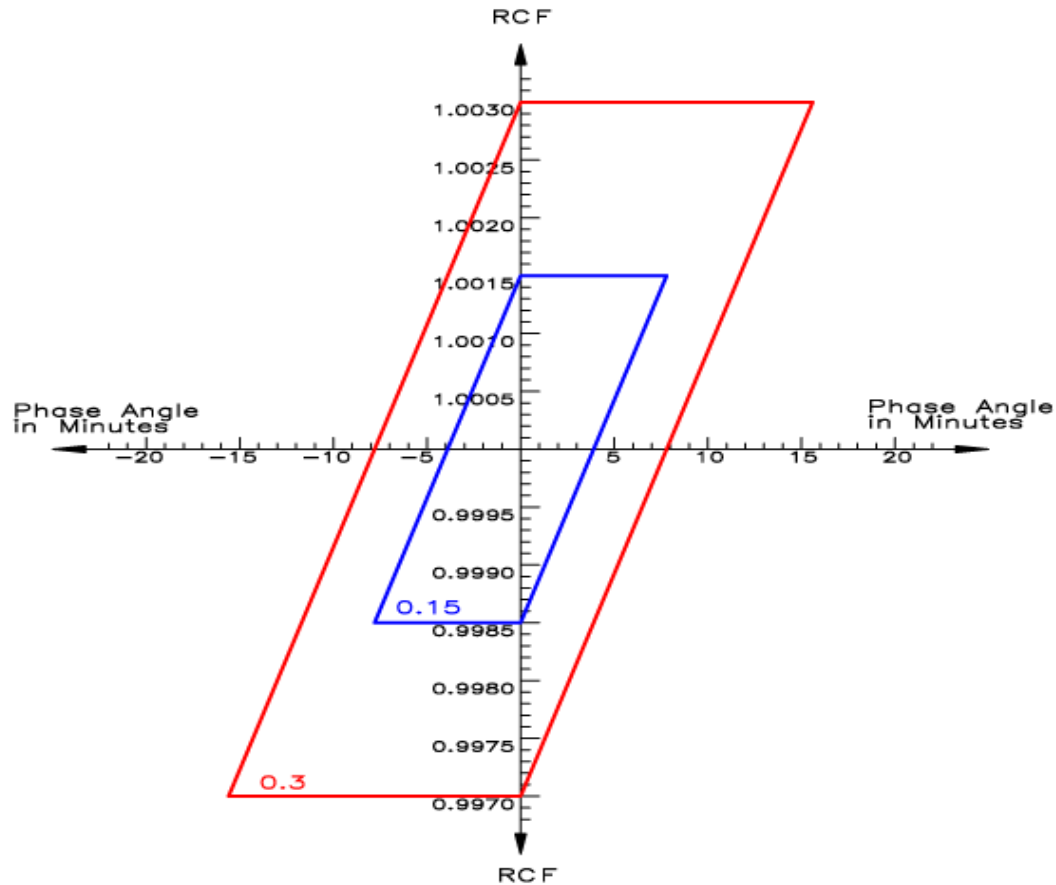

CT ERROR

CT error is typically negative...meaning less current in the secondary than there “should” be by the defined ratio.

CT error becomes increasingly negative as the primary current level decreases.

Negative Error = Lost Revenue

IDEALIZED TRANSFORMER CIRCUIT

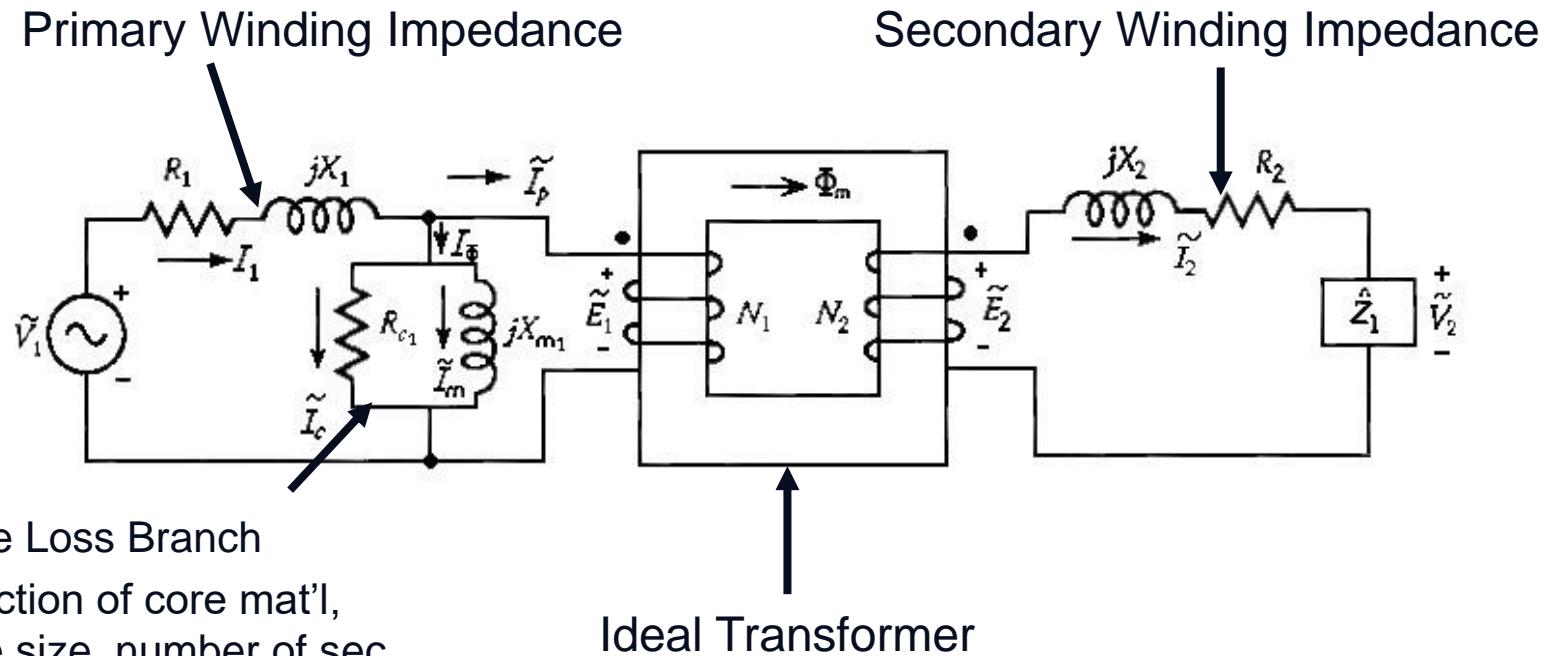

Core Loss Branch
(function of core mat'l,
core size, number of sec
turns)

This is an illustration that the excitation current is the current lost from the primary current that does not get to the meter. Accuracy is largely a function of minimizing this excitation current and why transformer accuracy is typically negative.

CT 0.3 ACCURACY CLASS

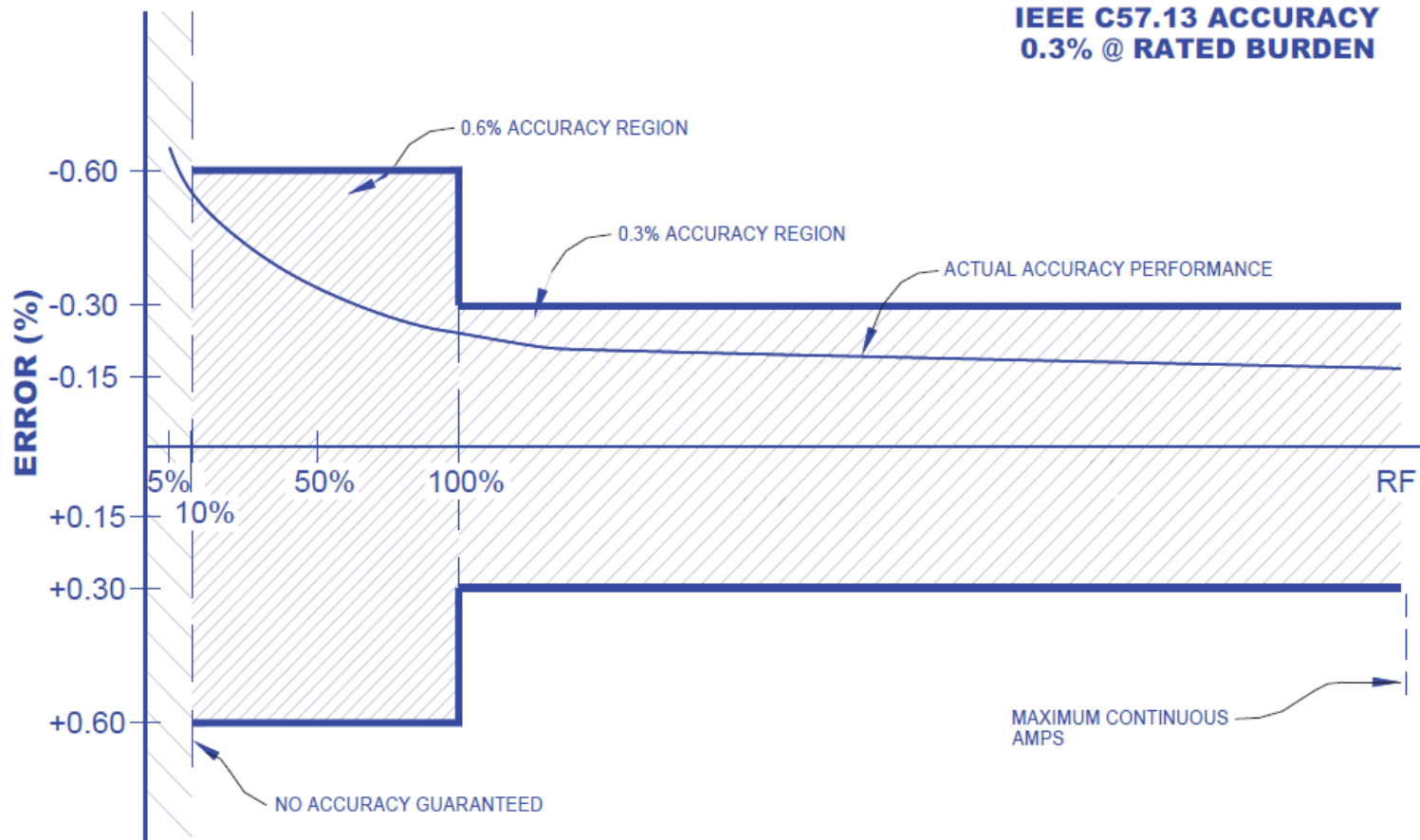

CT 0.15 ACCURACY CLASS

**IEEE C57.13.6 ACCURACY
0.15 @ RATED BURDEN**

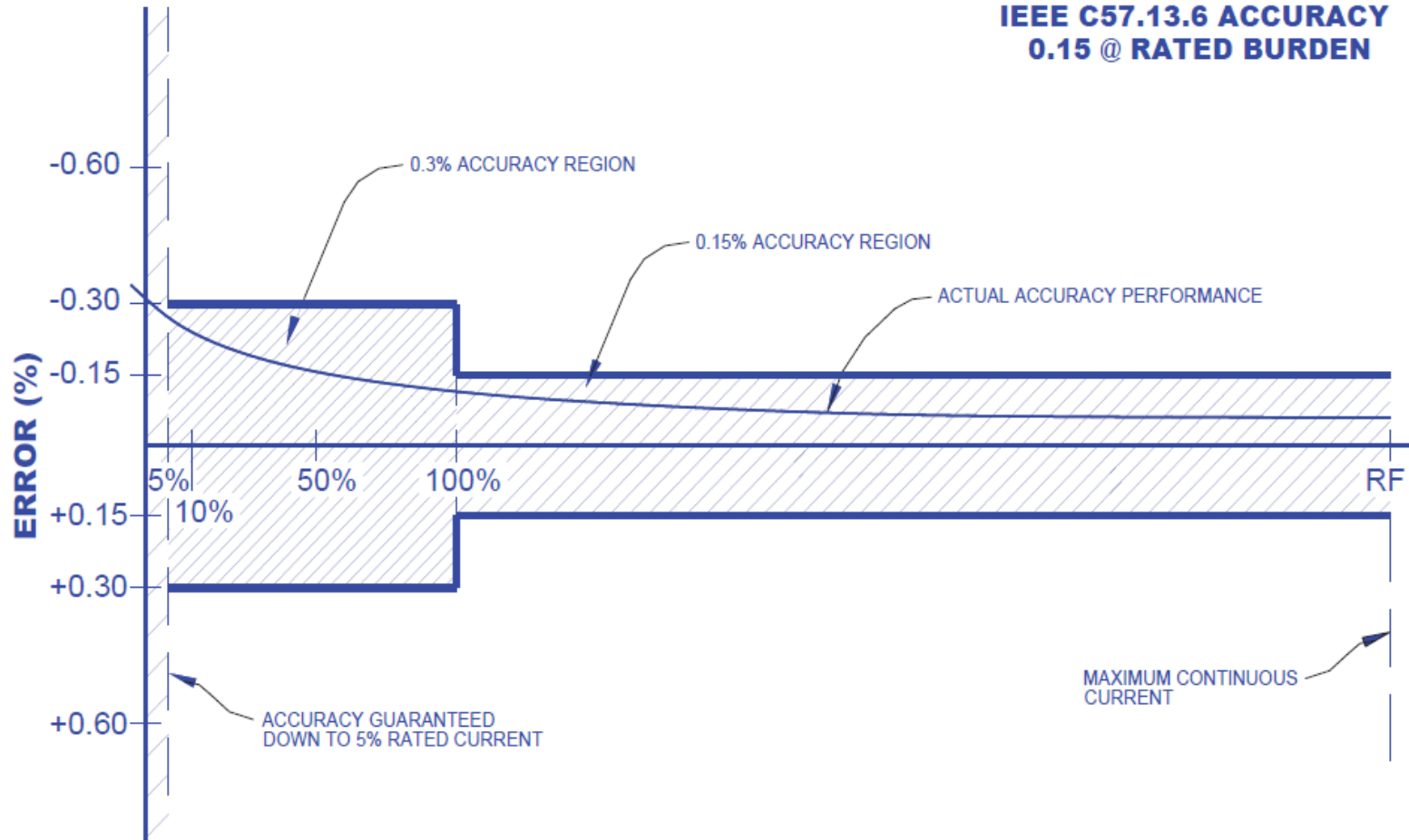

FUNDAMENTALS OF POLYPHASE FIELD METER TESTING AND SITE VERIFICATION

Functionality with Burden Present on the Secondary Loop

0.3% @ B0.1, B0.2, B0.5

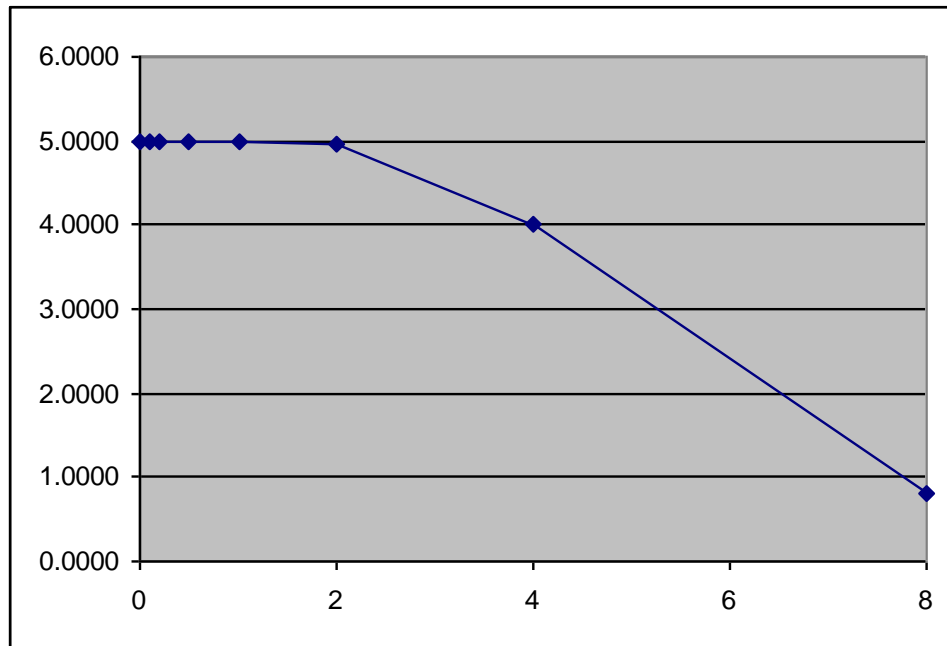

Initial Reading = 5Amps
 $0.3\% \times 5A = 0.015A$
 $5A - 0.015 = 4.985A$

Burden	Reading
0	5.0000
0.1	4.9999
0.2	4.9950
0.5	4.9900
1	4.9800
2	4.9500
4	4.0000
8	0.8000

SITE VERIFICATION: POTENTIAL SITE CHECK LIST

- Double check the meter number, the location the test result and the meter record.
- Perform a visual safety inspection of the site. This includes utility and customer equipment. Things to look for include intact down ground on pole, properly attached enclosure, unwanted voltage on enclosure, proper trimming and site tidiness (absence of discarded seals, etc.).
- Visually inspect for energy diversions (intentional and not). This includes broken or missing wires, jumpers, open test switch, unconnected wires and foreign objects on meters or other metering equipment. Broken or missing wires can seriously cause the under measurement of energy. A simple broken wire on a CT or VT can cause the loss of 1/3 to 1/2 of the registration on either 3 element or 2 element metering, respectively.
- Visually check lightning arrestors and transformers for damage or leaks.
- Check for proper grounding and bonding of metering equipment. Poor grounding and bonding practices may result in inaccurate measurements that go undetected for long periods of time. Implementing a single point ground policy and practice can reduce or eliminate this type of issue.
- Burden test CTs and voltage check PTs.

POTENTIAL SITE CHECK LIST (CON'T)

- Verify service voltage. Stuck regulator or seasonal capacitor can impact service voltage.
- Verify condition of metering control wire. This includes looking for cracks in insulation, broken wires, loose connections, etc.
- Compare the test switch wiring with the wiring at the CTs and VTs. Verify CTs and VTs not cross wired. Be sure CTs are grounded in one location (test switch) only.
- Check for bad test switch by examining voltage at the top and bottom of the switch. Also verify amps using amp probe on both sides of the test switch. Verify neutral connection to cabinet (voltage).
- Check rotation by closing in one phase at a time at the test switch and observing the phase meter for forward rotation. If forward rotation is not observed measurements may be significantly impacted as the phases are most likely cancelling each other out.
- Test meter for accuracy. Verify demand if applicable with observed load. If meter is performing compensation (line and/or transformer losses) the compensation should be verified either through direct testing at the site or by examining recorded pulse data.
- Loss compensation is generally a very small percentage of the overall measurement and would not be caught under utilities normal high/low checks. However, the small percentages when applied to large loads or generation can really add up overtime. Billing adjustments can easily be in the \$million range if not caught early.

POTENTIAL SITE CHECK LIST (CON'T)

- Verify metering vectors. Traditionally this has been done using instruments such as a circuit analyzer. Many solid state meters today can provide vector diagrams along with volt/amp/pf and values using meter manufacturer software or meter displays. Many of these desired values are programmed into the meters Alternate/Utility display. Examining these values can provide much information about the metering integrity. It may also assist in determining if unbalanced loads are present and if CTs are sized properly. The vendor software generally has the ability to capture both diagnostic and vector information electronically. These electronic records should be kept in the meter shop for future comparisons.
- If metering is providing pulses/EOI pulse to customers, SCADA systems or other meters for totalization they also should be verified vs. the known load on the meter.
- Verify meter information including meter multiplier (rework it), serial number, dials/decimals, Mp, Ke, Primary Kh, Kr and Rate. Errors in this type of information can also cause a adverse impact on measured/reported values.
- Verify CT shunts are all opened.



FUNDAMENTALS OF POLYPHASE FIELD METER TESTING AND SITE VERIFICATION

Ratio of Primary Current to Secondary Current

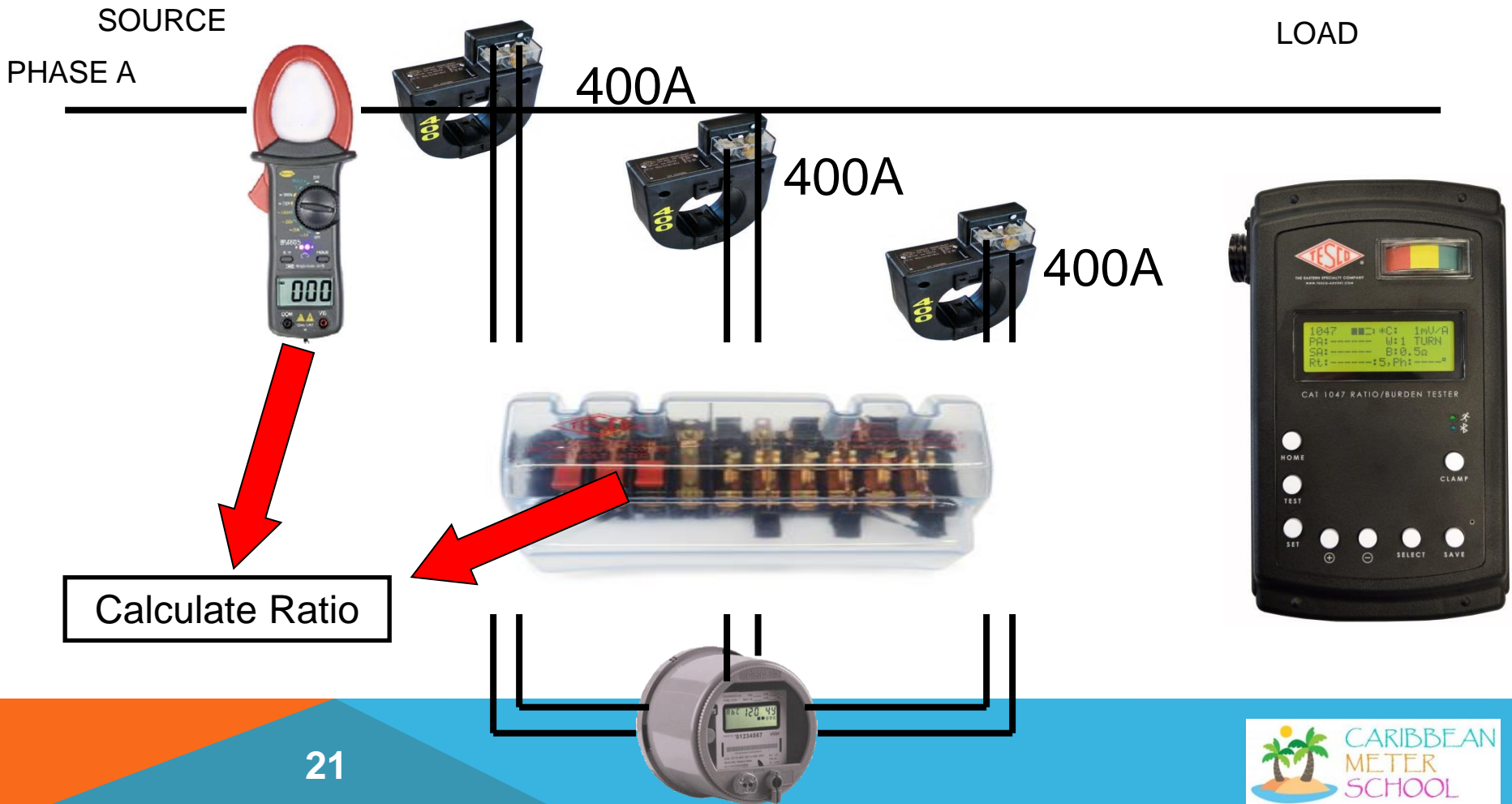

PERIODIC SITE INSPECTIONS.....

....Can Discover or Prevent:

- Billing Errors
- Bad Metering set-up
- Detect Current Diversion
- Identify Potential Safety Issues
- Metering Issues (issues not related to meter accuracy)
- AMR/AMI Communications Issues
- The need for Unscheduled Truck Rolls due to Undetected Field Related Issues
- Discrepancies between what is believed to be at a given site versus the actual setup and equipment at the site



SHOP TESTING

- Accuracy Testing
- Meter Communications Performance
- Software & Firmware Verification
- Setting Verification
- Functional Testing
- Disconnect/Reconnect Functionality and as left setting
- Ratio and accuracy testing
- Polarity checking
- Accuracy class determination



SHOP TESTING PROGRAMS

100% of all Transformers

- If not possible then sample testing of all and 100% of all those over a certain size for CT's and all VT's (generally not a large volume)

Transformer testing should include

- Ratio and accuracy testing
- Polarity checking
- Accuracy class determination

100% of all transformer rated meters

- If not possible then sample testing of all transformer rated meters and 100% of all those going into a certain size service and over

Meter testing should include:

- Software & Firmware Verification
- Setting Verification
- Functional Testing
- Disconnect/Reconnect Functionality and as left setting



SUMMARY

- Perform a shop test of every meter going into a transformer rated service. This includes a functional test as well as an accuracy test.
- Perform a shop test of every CT going into a transformer rated service.
- Perform a shop test of every VT going into a transformer rated service.
- Perform a base line site verification of every transformer rated service in your service territory.
- Use your AMI analytics to determine where there are misses:
 - No draw on one leg
 - Intermittent draw on one leg
 - Performing outside the rated range for the installed transformers
 - Reversed polarity
- Start checking for field issues all over again.
- Reduce the resources spent on self-contained metering by leveraging your AMI data as much as possible and creating new systems and procedures to replace older processes that did not have the availability of this type of data.

QUESTIONS AND DISCUSSION



Tom Lawton

TESCO – The Eastern Specialty Company
Knopp, Inc. – A TESCO Company
Bristol, PA and Emeryville, CA

215-688-0298 (cell)
215-785-2338 (office)

This presentation can also be found
on the TESCO web site:
www.tescometering.com