

OPERATING INSTRUCTIONS
for the
KNOPP TYPE KVTS
VOLTAGE TRANSFORMER TESTING SYSTEM

Leaflet Number 2-026-D

PM-19-10-003
Revision A

Initial Release: 9/12/19
Updated:



Knopp – A TESCO Company
1307 – 66th Street
Emeryville, California 94608
USA

(510) 653-1661
FAX: (510) 653-2202
sales@knoppinc.com www.knoppinc.com

Contents

| | | |
|-------|--|----|
| 1. | Description | 1 |
| 1.1 | General..... | 1 |
| 1.2 | Test Ranges | 1 |
| 1.3 | Test Burdens | 1 |
| 1.4 | Comparator (Type KATC-V)..... | 2 |
| 1.5 | System Accuracy | 2 |
| 1.6 | Self Check | 2 |
| 1.7 | Input Power Requirements..... | 2 |
| 2. | Installation | 3 |
| 2.1 | AC Power | 3 |
| 2.2 | Interlock | 3 |
| 2.3 | Cables for Transformer Connections..... | 4 |
| 2.4 | Circuit Breaker (KVTS)..... | 4 |
| 2.5 | Circuit Breaker (KATC-V Comparator) (See separate KATC-V Manual)..... | 4 |
| 3. | Operation | 5 |
| 3.1 | Description of Controls and Indicators..... | 5 |
| 3.1.1 | POWER switch is a combination switch/circuit breaker /indicator for the 120 VAC <i>control</i> circuitry. | 6 |
| 3.1.2 | VOLTAGE ON (white) push-button applies power to the <i>loading</i> circuitry. The red lamp below this control is lit when the loading circuitry is energized. Note that both the fine and coarse variacs must be at zero before pressing this button or no voltage will be applied by the KVTS. | 6 |
| 3.1.3 | VOLTAGE OFF (red) push-button is used to de-energize the <i>loading</i> circuitry. | 6 |
| 3.1.4 | BURDEN select switch determines the ANSI burden to be inserted in the secondary of the transformer-under-test. The two terminals below this switch are to be used to connect an external burden. | 6 |
| 3.1.5 | VOLTAGE-FINE variac provides fine control of the test voltage. | 6 |
| 3.1.6 | VOLTAGE-COARSE variac provides coarse control of the test voltage. | 6 |
| 3.1.7 | CIRCUIT BREAKER <i>located below the writing surface</i> protects the power input to the KVTS. | 6 |
| 3.1.8 | HV JUMPER is used to select the appropriate voltage range on the supply and precision transformers. | 6 |
| 3.2 | Operating Procedure..... | 7 |
| 3.2.1 | Connection of the Transformer-under-Test..... | 7 |
| 3.2.2 | Testing Procedure | 9 |
| 4. | Maintenance..... | 10 |
| 4.1 | Knopp One-to-One Test..... | 10 |
| 5. | Warranty..... | 13 |

1. Description

1.1 General

The Knopp Voltage Transformer Test System (Type KVTS), when used with the Knopp Type 2J4 or 2J6 Transformer Set, will check the accuracy of instrument transformers having primary ranges up to 14,400 volts (48,000 volts for 2J6). Use of a microprocessor-based automatic, auto-ranging comparator provides minimum measurement time and maximum accuracy.

1.2 Test Ranges

The primary ranges depend on the particular transformer test set used:

Type 2J4: 120/240/480/600/2400/4200/4800/
7200/8400/12,000/ and 14,400 volts.

Type 2J4-4: 120/240/288/300/480/600/2400/4200/
4800/7200/8400/12,000/ and 14,400
volts.

Type 2J6-1: 14,400/18,000/20,760/36,000 volts.

Type 2J6-2: 14,400/16,800/24,000/36,000 volts.

Type 2J6-3: 14,400/21,000/24,000/36,000 volts.

Type 2J6-5: 14,400/24,000/36,000/48,000 volts.

Type 2J6-6: 14,400/21,000/24,000/36,000/48,000
volts.

1.3 Test Burdens

The following test burdens are switch selectable:

W, X, M, Y, Z, and ZZ

Provisions are also made for use of an external burden.

1.4 Comparator (Type KATC-V)

The comparator has the following features:

- **Automatic and autoranging**—providing minimum measurement time (typically a few seconds after adjustment of test voltage).
- **Digital display of test voltage and test results.** Ratio error can be displayed in Percent Error or Ratio Correction Factor (RCF). Phase error can be displayed in Minutes or Milliradians.
- **Accuracy class** for which the transformer-under-test (TUT) qualifies is calculated and digitally displayed.
- **Protective circuitry** which senses error conditions such as wrong ratio or wrong polarity and then automatically removes power from the KVTS loading circuitry.

1.5 System Accuracy

The combined error of the precision voltage transformer and the transformer comparator is not greater than $\pm 0.025\%$ on ratio and ± 2 minutes on phase angle at 120 volts.

1.6 Self Check

The precision transformer calibration can be periodically checked by the Knopp One-to-One method, whereby the ratio and phase angle performance can be quickly and accurately checked without the use of an external reference standard. Refer to Section 4.1 of this manual for more information.

1.7 Input Power Requirements

120 VAC, 60 Hz., Single-phase, at 20 amps (maximum).

2. Installation

2.1 AC Power

The KVTS is shipped with the power cable attached and routed through the rear panel. For shipping purposes, the cable is then inserted through the cutout in the lower, rear panel of the KVTS console. Remove the cable from its shipping position. The end of the cable is terminated with a twist-lock type of connector. This type of connector is used to lessen the chance of the KVTS being inadvertently unplugged while a test is in progress.

Attached to the plug at the end of the power cable is the mating female twist-lock connector. This connector should be securely mounted to the wall prior to plugging in the KVTS.

NOTE

It is very important that the ground connection be attached to a solid earth ground.

If desired, the twist-lock plug may be removed from the power cable and the cable may be directly wired to a 120 volt supply. If this is done it is still important that the ground lead be connected to a solid earth ground.

2.2 Interlock

Remove the ***lower front panel*** to gain access to the connection panel.

The interlock terminals on the connection panel are provided if the 2J4 (and/or 2J6) and the TUT will be located in a separate cage for safety purposes. In this case, the interlock terminals should be wired to a switch on the cage door such that when the door is open, the switch is open. The open switch causes the KVTS to remove voltage from the transformers inside the cage. If this feature is used, remove the jumper from the INTERLOCK terminals.

KNOPP STRONGLY RECOMMENDS THAT THE 2J4 (AND/OR 2J6) TRANSFORMER BE PLACED IN A SAFETY CAGE AND THAT THE INTERLOCK TERMINALS BE CONNECTED TO A SWITCH ON THE DOOR OF THAT CAGE. FAILURE TO DO SO COULD EXPOSE THE OPERATOR TO LETHAL VOLTAGES.

2.3 Cables for Transformer Connections

These cables are shipped connected to the terminal board, coiled up, and laying on the floor of the console. Access to these cables is provided by the cutout in the lower, rear panel of the KVTS.

Also included with the cables is the "HV jumper" (high voltage jumper) which is used to select the proper voltage range corresponding to the transformer-under-test.

Refer to Drawing Number 11469 for information on how to connect the cables to the 2J4 or 2J6 transformer set.

2.4 Circuit Breaker (KVTS)

Check the circuit breaker located below the writing surface to ensure that it is in the ON position.

2.5 Circuit Breaker (KATC-V Comparator) (*See separate KATC-V Manual*)

This circuit breaker protects the internal circuitry of the KATC-V Comparator and is located on the rear panel of the Comparator. However, if it tripped due to excessive errors, the KATC-V will still display results. These results will be **erroneous**. This breaker must be **ON**.

To gain access to this breaker, the rear panel of the KVTS console must be removed. It is secured by six (6) screws.

The Circuit Breaker is shown below:

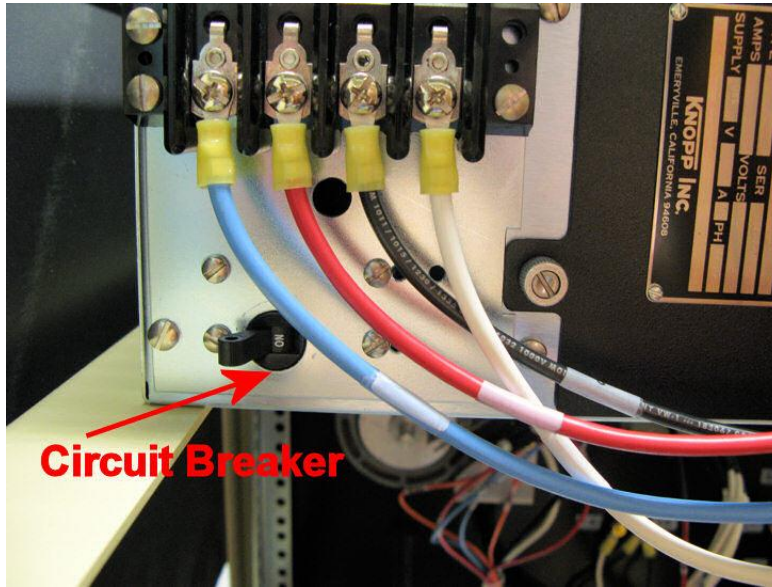

3. Operation

NOTE: See separate instructions for the KATC-V comparator.

3.1 Description of Controls and Indicators



- 3.1.1 POWER** switch is a combination switch/circuit breaker /indicator for the 120 VAC *control* circuitry.
- 3.1.2 VOLTAGE ON (white)** push-button applies power to the *loading* circuitry. The red lamp below this control is lit when the loading circuitry is energized. Note that both the fine and coarse variacs must be at zero before pressing this button or no voltage will be applied by the KVTS.
- 3.1.3 VOLTAGE OFF (red)** push-button is used to de-energize the *loading* circuitry.
- 3.1.4 BURDEN** select switch determines the ANSI burden to be inserted in the secondary of the transformer-under-test. The two terminals below this switch are to be used to connect an external burden.
- 3.1.5 VOLTAGE-FINE** variac provides fine control of the test voltage.
- 3.1.6 VOLTAGE-COARSE** variac provides coarse control of the test voltage.
- The **amber** light (**READY**) located below the VOLTAGE ON push-button is on when both variacs are at zero—indicating that the loading circuitry can be energized (TEST VOLTAGE cannot be applied when either variac is off zero).
- The **red** light (**ON**) located next to the **amber** light indicates that the test Voltage is applied to the transformer test set and the transformer-under-test.
- 3.1.7 CIRCUIT BREAKER** *located below the writing surface* protects the power input to the KVTS.
- 3.1.8 HV JUMPER** is used to select the appropriate voltage range on the supply and precision transformers.

3.2 *Operating Procedure*

3.2.1 Connection of the Transformer-under-Test

Refer to Drawing Number 11469 for instructions on connecting the transformer-under-test or see the diagram on the next page:

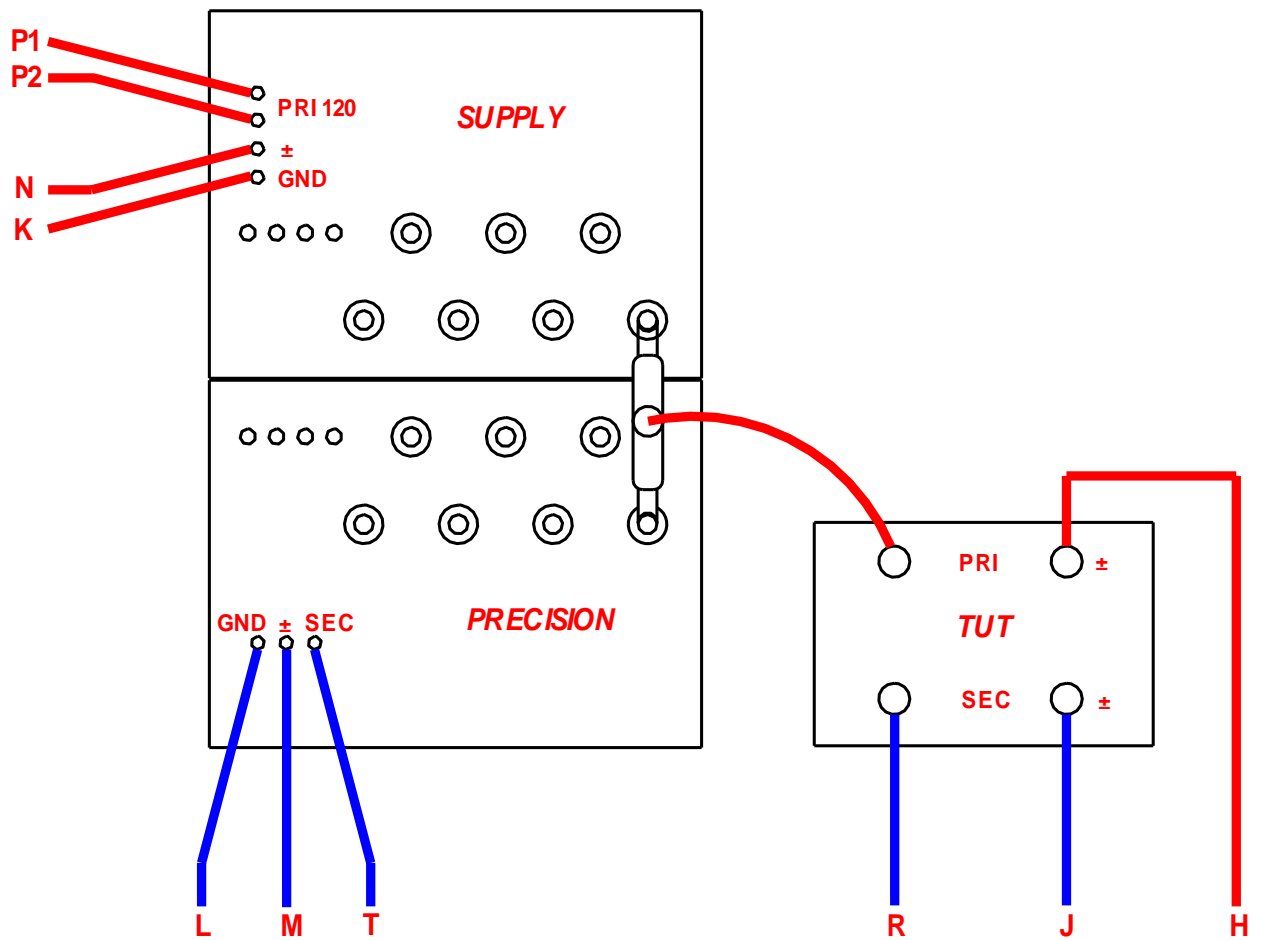

2J4 -- KVTS CONNECTIONS

3.2.2 Testing Procedure

- a. Turn the KVTS and KATC-V power switches to ON. These switches can be left on throughout the working day.
- b. Using the HV jumper, select the appropriate range on the 2J4 (or 2J6) set.
- c. Select the desired burden on the BURDEN switch.
- d. Check to see that the **amber** READY lamp is lit. If not, turn the coarse and fine control variacs to zero. The loading circuitry cannot be energized until the **amber** lamp is lit (variacs at zero).
- e. Press and release the VOLTAGE ON push-button.
- f. Adjust the COARSE and FINE control variacs for the desired **secondary** test voltage as indicated by the KATC-V.

IT IS IMPORTANT TO NOTE THAT WHENEVER VOLTAGE IS PRESENT ON THE 2J4 (OR 2J6) TRANSFORMER SET ALL TERMINALS ON THOSE TRANSFORMERS ARE ENERGIZED.

IT IS THE OPERATOR'S RESPONSIBILITY TO BE AWARE OF, AND FOLLOW, ALL COMPANY SAFETY RULES WHICH DEAL WITH WORKING IN THE PRESENCE OF HIGH VOLTAGES.

- g. After the KATC-V readings stabilize, press HOLD/PRINT on the KATC-V.
- h. Return the variacs to zero.
- i. Record the KATC-V readings. If a computer is connected, the readings may be sent to the computer by pressing the HOLD/PRINT button a second time.
- j. Press RESET on the KATC-V to prepare for the next measurement.
- k. Press VOLTAGE OFF after all measurements on a given transformer are complete.

NOTE: If excessive error voltage exists during the measurement, such as would be caused by wrong polarity or wrong ratio, the KATC-V will automatically de-energize the loading circuitry and sound an alarm. If this occurs, return both variacs to zero, correct the condition, press RESET, and proceed.

4. Maintenance

4.1 *Knopp One-to-One Test*

In order to check the overall performance of the equipment, the One-to-One test can be periodically performed. The results can then be compared to the data originally supplied with the equipment. Connection instructions for the One-to-One test are given below. Drawing Number 11469 contains more information regarding connections for this test.

To make connections for the One-to-One Test (see diagram on next page)

- a. Remove the transformer-under-test.
- b. H and J are wired to ground and should be laid aside.
- c. Connect HV jumper to 120 V terminals.
- d. Join HV and R and isolate the junction from ground and other conducting points.

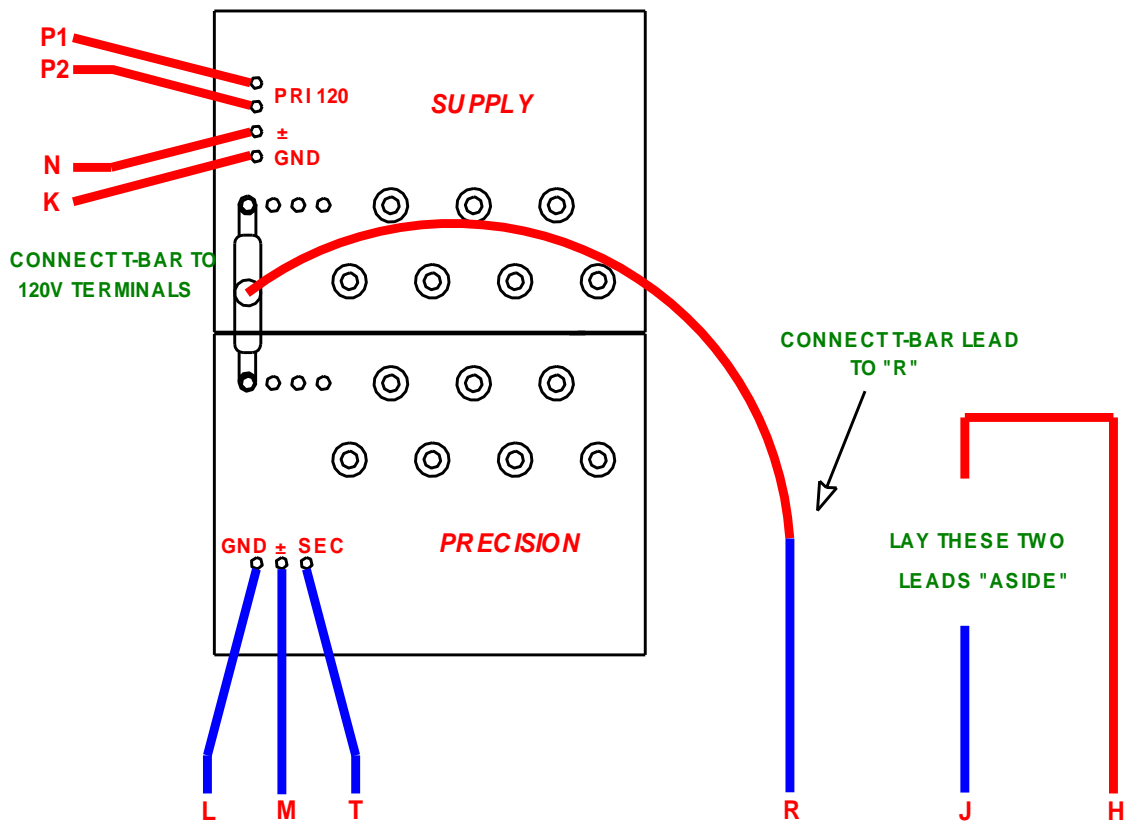

2J4 -- KVTS CONNECTIONS

ONE-TO-ONE TEST

To perform the One-to-One Test:

The BURDEN switch should be in the EXTERNAL position.

Refer to the One-to-One Data originally supplied with the transformer. Note the voltages at which the data were obtained (usually 105, 110, 120, and 130 volts).

- a. Turn the KVTS and KATC-V power switches ON.
- b. Check to see that the amber READY lamp is lit. If not, turn the coarse and fine control variacs to zero.
- c. Press and release the VOLTAGE ON push-button.
- d. Adjust the COARSE and FINE control variacs for the desired test voltage as indicated by the KATC-V.
- e. After the KATC-V readings stabilize, press HOLD/PRINT on the KATC-V.
- f. Return the variacs to zero.
- g. Record the KATC-V readings. If a computer is connected, the readings may be sent to the computer by pressing the HOLD/PRINT button a second time.
- h. Press RESET on the KATC-V to prepare for the next measurement.
- i. Press VOLTAGE OFF after all measurements are complete.

The results should agree with the One-to-One data originally supplied with the equipment to within ± 1.0 minutes and $\pm 0.01\%$ on phase angle and ratio error, respectively.

NOTE

In this One-to-One test, the magnitudes of PHASE ANGLE and PERCENT RATIO ERROR displayed on the KATC-V are valid, but the signs are opposite. For example, if the ratio error is read as +0.2%, the actual error is -0.2% and the RCF would read 1.00200 but actually is 0.99800. If the phase angle reads +4.5 minutes (+1.3 milliradians), it actually is -4.5 minutes (-1.3 milliradians).

5. Warranty

The Knopp Type KVTS Voltage Transformer Testing System is warranted against defects in materials and workmanship for a period of ONE YEAR.

If the KVTS does not perform in accordance with stated operating specifications during the warranty period, necessary parts and assistance will be supplied under warranty to restore the equipment to service.

Normal service is accomplished through telephone consultation with the Knopp Engineering Department.

Parts are shipped by overnight carrier.

You Can Contact Knopp At:

**510-653-1661 or
sales@knoppinc.com**

APPROVAL/ CHANGE RECORD

Approval Record

Originator: Jameson Kern Title: Technical Manager Date: 12-Sep-19

Change Record

| Revision No. | Date | Responsibility | Description |
|--------------|-----------|----------------|-------------|
| A | 12-Sep-19 | Jameson Kern | Initial |
| | | | |